

N-96-01
II-A-178

United States
Environmental Protection
Agency

Office of
Noise Abatement and Control
Washington, DC 20460

EPA REPORT NO. 550/9-82-105
April 1982

Noise

EPA

GUIDELINES FOR NOISE IMPACT ANALYSIS

W-96-01
II-A-170

TECHNICAL REPORT DATA <i>(Please read instructions on the reverse before completing)</i>		
1. REPORT NO. 550/9-82-105	2.	3. RECIPIENT'S ACCESSION NO.
4. TITLE AND SUBTITLE Guidelines for Noise Impact Analysis	5. REPORT DATE April 1982	
	6. PERFORMING ORGANIZATION CODE EPA/CNAC	
7. AUTHOR(S)	8. PERFORMING ORGANIZATION REPORT NO. 550/9-82-105	
9. PERFORMING ORGANIZATION NAME AND ADDRESS Office of Noise Abatement and Control U.S. Environmental Protection Agency 401 M St. S.W. Washington, D.C. 20460	10. PROGRAM ELEMENT NO.	
	11. CONTRACT/GRANT NO.	
12. SPONSORING AGENCY NAME AND ADDRESS (Report #9)	13. TYPE OF REPORT AND PERIOD COVERED	
	14. SPONSORING AGENCY CODE EPA/CNAC	
15. SUPPLEMENTARY NOTES		
16. ABSTRACT The purpose of the guidelines proposed in this report is to provide decision-makers, in both the public and private sectors, with analytic procedures which can be uniformly used to express and quantify impacts from noise, so that such impacts can be readily understood and fully considered within the comparative evaluations which constitute noise environment decisions. The procedures contained within the guidelines are applicable to the preparation of environmental noise assessments and environmental impact description of noise environment changes would be useful. The procedures allow a user to arrive at an objective, and for most situations, quantitative definition of noise impact. In many situations, the procedures will allow the calculation of a single number descriptor which expresses the total noise impact of a proposed project on the population exposed. The quantification methods recommended for impact assessment in these guidelines are further developments of the Fractional Impact Methodology used for assessing the health and welfare effects of a noise environment. Three principal types of noise and vibration environments are considered: general audible noise; special noises; and vibrations. There is a separate chapter for each of these principal types of environment.		
17. KEY WORDS AND DOCUMENT ANALYSIS		
a. DESCRIPTORS	b. IDENTIFIERS/OPEN ENDED TERMS	c. GOSAT Field/Group
Noise Impact Noise Criticism General Audible Noise High-Energy Impulse Noise Infrasound Ultrasound Vibration	Noise Effects Noise Assessment Noise	
18. DISTRIBUTION STATEMENT EPA mailing list NTIS	19. SECURITY CLASS (This Report) Unclassified	21. NO. OF PAGES 214
	20. SECURITY CLASS (This page) Unclassified	22. PRICE

EPA REPORT NO. 550/9-82-105
April 1982

GUIDELINES FOR NOISE IMPACT ANALYSIS

This report has been approved for general availability. The contents of this report reflect the views of the contractor, who is responsible for the facts and the accuracy of the data presented herein. This report does not necessarily reflect the official views or policy of EPA. This report does not constitute a standard, specification, or regulation.

PERMISSION IS GRANTED TO REPRODUCE THIS MATERIAL WITHOUT FURTHER CLEARANCE

FOREWORD

The purpose of the guidelines proposed in this report is to provide decision-makers, in both the public and private sectors, with analytic procedures which can be uniformly used to express and quantify impacts from noise, so that such impacts can be readily understood and fully considered within the comparative evaluations which constitute noise environment decisions. The procedures contained within the guidelines are applicable to the preparation of environmental noise assessments. Adherence to the procedures within the guidelines is strictly voluntary. The guidelines are neither mandatory nor regulatory in intent. Specific numbers which appear in the guidelines should not be construed as standards, nor are they intended to supplant any locally established community noise level limits or decisions on environmental acceptability with respect to noise as fostered by certain states, municipalities, or other governmental jurisdictions. Instead, the guidelines are offered here as simply a tool to allow decision-makers to consider trade-offs between environmental benefits and costs anew for potentially noisy projects.

The guidelines are based on the deliberations of the Committee on Hearing, Bioacoustics and Biomechanics (CHABA) Working Group 69, National Academy of Sciences (NAS), from 1972 to 1976, in response to a request in 1972 by the U.S. Environmental Protection Agency (EPA). In early 1977, recommended procedures were published by the National Academy of Sciences in a document entitled "Guidelines for Preparing Environmental Impact Statements on Noise." That document provided a comprehensive set of procedures for specifying the physical descriptions of environmental noise and vibration, and methods for assessing the degree of impact on people associated with these environments.

The technical approaches proposed by NAS underwent several significant changes during the period of CHABA working group activity as a result of

working group deliberations, public discussions, and presentations at national and international technical meetings. Under the constraint that the procedures contained within the guidelines must reflect a compromise among factors of practicality, economy, desired accuracy, and specificity, the working group tried to be responsive to the numerous suggestions received from government agencies, industries, and the scientific community. The proposed procedures were tried out by several of the working group members and others, and shortcomings and gaps were identified. This led to joint working group research activities or to efforts by individual members. Many of these individual efforts, which had their roots in the working group activities, were conducted and sponsored under other government or private industry programs and have been separately published in the meantime. Similarly, some agencies, faced with the need for operational decisions, used concepts from the proposed guidelines in their publications; those publications are included among the references cited in the guidelines. Some of the proposed methods contained within the guidelines have been officially adopted by several agencies. Further, close liaison was maintained between the working group and several writing groups working on related items under the American National Standards Institute (ANSI) Acoustical Standards Committees. In summary, the working group tried to be responsive to all potential users concerned and tried to reach consensus wherever possible.

During the summer of 1977, EPA distributed copies of the NAS report to Federal agencies and other interested parties with a request for comments. On June 30, 1978, a request for further comments was published in the Federal Register (43 FR 28549). Both of these actions were taken to provide an opportunity for additional viewpoints and expertise to be considered in a proposed

BEST COPY AVAILABLE

revision of the NAS report. EPA then carried out a detailed, step-by-step analysis of the issues raised during the comment period in order to improve the overall accuracy, usage, and general readability of the document.

Conceptually, the latest draft version of the guidelines contains the same basic procedures delineated in the NAS guidelines published in 1977. However, because of some refinements in the assessment methodologies, EPA in February 1981, extended to the original commenters an opportunity to comment on the final draft version. At the same time, other Federal agencies were informed as to the existence of the revised draft, and were afforded an opportunity to comment. Comments were also solicited from the National Academy of Sciences, and from other individuals and organizations who specifically requested an opportunity to review the draft revision to the guidelines. Accordingly, revisions have been made to the 1981 draft report to reflect the additional comments received.

Finally, it is only fair to say that in a report as comprehensive and exploratory as this one, not all working group members agreed with all the details in the report. However, they all agreed with its essential concepts and the general approaches, and hoped that the details would be worked out, corrected, and fall in place as experience with the proposed guidelines is gained. Similarly, not all of those commenting on the report will be satisfied with the revisions which have been made. In the face of continued gaps in knowledge, honest differences of opinion will undoubtedly remain about the procedures recommended in this publication. Nevertheless, it was important for these guidelines to be published as soon as possible in order to assist in providing guidance for uniform methods of noise impact assessment. It should be recognized that it may be necessary to update these guidelines in

the future. The guidelines are open to revision as new information becomes available.

These revised guidelines were prepared under the guidance of the Office of Noise Abatement and Control, U.S. Environmental Protection Agency. EPA wishes in turn to acknowledge the contributions of the members of Working Group 69 of CHABA to the development of these recommended guidelines. We also wish to thank the members of CHABA Working Group 84 for their assistance in the development of the method for assessing human response to high-energy impulse noise. We extend further thanks to all the commentators who provided us with most helpful comments which led to the revision of the guidelines, and who demonstrated noble patience and forbearance during the lengthy revision process. Finally, we wish to express our sincere appreciation to Frederick L. Hall of McMaster University who assisted us in analyzing the comments and drafting the revision, and whose insights and suggestions proved invaluable to the final issuance of these guidelines.

Committee on Hearing, Bioacoustics, and Biomechanics

Working Group 69
on
Evaluation of Environmental Impact of Noise

Henning E. Von Gierke, Chairman
Wright-Patterson AFB

Clifford Bragdon
Georgia Institute of Technology

David H. Mudarri
Environmental Protection Agency

Kenneth Eldred
Ken Eldred Engineering

John Reed
Sandia Laboratories

William J. Galloway
Bolt Beranek and Newman, Inc.

Paul D. Schomer
Construction Engineering Laboratory

Jeffrey Goldstein
Environmental Protection Agency

Theodore Schultz
Bolt Beranek and Newman, Inc.

Ira Hirsh
Central Institute for the Deaf

Simone Yaniv
National Bureau of Standards

Daniel L. Johnson
Wright-Patterson AFB

Robert Young
San Diego, CA

Working Group 84
on
Human Response to Impulse Noise

William J. Galloway, Chairman
Bolt Beranek and Newman, Inc.

Daniel L. Johnson
Wright-Patterson AFB

Paul D. Schomer
Construction Engineering Laboratory

Karl D. Kryter
SRI International Inc.

Peter J. Westervelt
Brown University

CONTENTS

<u>Section</u>	<u>Title</u>	<u>Page</u>
1.	Introduction	1
1.1	Purpose of the guidelines	1
1.2	Overview of the approach	3
1.3	Structure of the guidelines	7
1.3.1	Preliminaries	8
1.3.2	General audible noise	12
1.3.3	Special noises	13
1.3.4	Vibration	14
1.3.5	Potential changes in population	14
1.3.6	Examples	15
1.4	Other considerations	16
1.4.1	Projects which reduce noise	16
1.4.2	Temporary projects	17
1.4.3	Uncertainties in the analysis	18
2.	General audible noise	19
2.1	Basic screening procedures	20
2.1.1	Measures for the description of general audible noise	23
2.1.2	Determining the yearly day-night sound level	25
2.1.3	Determining the population affected by the noise of the proposed project	30
2.2	Health and welfare effects	33
2.2.1	Human noise exposure criteria	33
2.2.2	Quantification of the noise impact	41
2.3	Severe health effects	52
2.3.1	Human noise exposure criteria	54
2.3.2	Quantification of the impact	60
2.4	Environmental degradation	62
2.5	Treatment of temporary projects	64
2.6	Practical Example	66
3.	Special noises	71
3.1	High-energy impulse noise	71
3.1.1	Description of high-energy impulse noise	72
3.1.2	Human noise exposure effects of high-energy impulse noise	75
3.1.3	Structural damage criteria for impulse noise	80
3.2	Infrasound	85
3.2.1	Description of infrasound	85
3.2.2	Human noise exposure effects of infrasound	85
3.3	Ultrasound	87
3.3.1	Description of ultrasound	87
3.3.2	Human effects of ultrasound	88
3.4	Noises with information content	88
4.	Vibration	89
4.1	Human effects of vibration	89

CONTENTS (Continued)

<u>Section</u>	<u>Title</u>	<u>Page</u>
4.1.1	Description of building vibration	90
4.1.2	Human vibration exposure criteria	90
4.1.3	Quantification of the impact	95
4.2	Structural effects of vibration	98
5.	Summary of noise impact analysis	100
5.1	Purpose and structure of the guidelines	100
5.2	Analysis of impacts of general audible noise	101
5.3	Analysis of impacts due to special noises	104
5.4	Analysis of impacts due to vibration	105
References		R-1
Appendix A	Acoustical terms and symbols used in the guidelines, and some mathematical formulations for them	A-1
B	Environmental noise measures and procedures	B-1
	1. Environmental noise measures and their purposes in Federal programs	B-2
	2. Estimating L_{dn} from other noise measures	B-3
C.	Summary of human effects of general audible noise	C-1
D.	Measurement of and criteria for human vibration exposure	D-1
E.	Example application of guideline procedures for general audible noise	E-1

LIST OF TABLES

<u>Table</u>	<u>Title</u>	<u>Page</u>
1	Summary of methods for noise impact analysis	6
2	Yearly day-night sound level as estimated by population density	29
3	Values of the weighting function for general adverse response	47
4	Average hearing loss as a function of 8-hour L_{eq}	58
5	Criterion function for severe health effects	60
6	Sample data presentation: future noise levels without proposed project	67
7	Sample data presentation: future noise levels of project alone	68
8	Sample data presentation: future levels from all sources combined	69
9	Sample data presentation: special situations	70
10	Values of weighting function for high energy impulse noise	79
11	Conversion of L_{Cdn} to L_{dn} via equal annoyance	81
12	Basic threshold acceleration values for acceptable vibration environments	92

LIST OF FIGURES

<u>Figure</u>	<u>Title</u>	<u>Page</u>
1	Preparation of a noise impact analysis	5
2	Flow chart and worksheet	9
3	Screening diagram	21
4	Summary of annoyance data from 12 surveys showing close agreement	37
5	Comparison of new annoyance function with previous functions	39
6	Suggested descriptors for various situations	50
7	Comparison of curvilinear function and fractional impact linear function	53
8	Potential hearing damage risk for daily exposure to 8-hour equivalent sound levels	59
9	Recommended relationship for predicting community response to high energy impulsive sounds	78
10	Infrasound criteria	86
11	Weighting characteristic for building vibration in terms of human responses for the frequency range 1 to 80 Hz	91
12	Vibration criteria for residential areas	94
13	Percentage of population complaining as a function of peak acceleration	96
14	Types of analyses suggested	103

CHAPTER 1

INTRODUCTION

It is the policy of the United States Government to consider the potential adverse impact on the environment of all proposed federal actions and projects. Many states and local governments have similar policies. The purpose of such policies is not merely to provide a catalog of the adverse environmental impacts of a project (which may have already received tacit approval). Rather, the purpose is to provide a description of the environmental consequences of a possible project, so that an understanding of those consequences can be an integral part of the decision on the project. In order for this to occur, it is necessary for the environmental effects to be expressed in a manner which can be readily understood by the decision-maker, and by the general public whose participation in such decisions is usually encouraged by all levels of government.

1.1 Purpose of the guidelines

One of the potential environmental consequences of many proposed actions or projects is a change in the noise and vibration environment. The "action" may be the building of a new refinery, development of a new mine, construction of a road, use of a new piece of machinery, etc. It may involve the enlargement or the reduction in size of an existing facility, or an effort to make a given facility quieter. It may be the promulgation and enforcement of a new noise abatement regulation. It may be the temporary noisy construction phase of an inherently quiet facility. Or, with no change in the noise environment, the action may entail a change in land use or population density in a neighborhood. Any proposed change that will significantly affect either (a) the amount of noise generated or (b) the number of people exposed to it, will

result in noise-related environmental impacts. These guidelines contain procedures which can be used to describe and quantify those noise related impacts. These procedures are primarily intended for use during initial planning stages of projects in order that the potential environmental noise effects of proposed actions can be identified and considered early in the decision process, and so that appropriate noise mitigation measures can be conveniently implemented.

The users of this document are expected to be federal agencies, state and local governmental agencies, industries, environmental groups, and individuals. The procedures described here are applicable to the preparation of environmental assessments and environmental impact statements, and to any other situation in which a description of noise environment changes would be useful. Although individual agencies have their own specific procedures, in most instances the approach described here is consistent with those procedures. These guidelines are not intended to replace existing approaches, but to complement and extend them, by showing how to proceed from a description of noise levels to a quantitative description of the impacts of noise on people. It is hoped that this document will assist in achieving nationwide consistency in dealing with noise problems, and provide an objective and uniform evaluation of the noise impacts.

The approaches described in these guidelines are not mandatory, nor are specific numbers which appear in the guidelines intended to be construed as standards. The guidelines are offered as an aid to the treatment of noise impacts in the preparation of environmental assessments, reviews, and impact statements. Paraphrasing a statement by the Council on Environmental Quality, these guidelines are intended to help public officials make decisions which are based on an understanding of environmental consequences, and to take

actions that protect, restore, and enhance the environment [1*, p. 25233]. The purpose of these guidelines, then, is to present procedures which can be used to express noise impacts in terms which are easily understood by decision-makers, so that those impacts can be fully incorporated in the comparative evaluations which constitute the decision.

1.2 Overview of the approach

The guidelines are based on the philosophy that the technical approach, the descriptors of the noise environment, the measurement and prediction methods, the evaluation criteria, and the techniques for impact assessment should be as simple as possible consistent with reasonable accuracy. To the extent that they are also uniform across different projects, public understanding of noise impacts will be improved.

It appears feasible to follow these principles to arrive at an objective, and for most situations, quantitative definition of the noise impact. In many situations, it will be possible to calculate a single number which expresses the total noise impact of a proposed project on the population exposed. When this single number index can be produced, the prospects are enhanced for a more objective and rational comparison of noise with a host of other criteria or impacts associated with specific projects. Quantitative tradeoff studies are made possible--for example between noise impacts and societal benefits. In some cases, this level of quantification might seem unwarranted, or overly mechanistic. For such cases, the guidelines suggest a tabulation, in 5 decibel (dB)** increments, of the land area or number of people affected by

*Numbers in square brackets refer to the reference list at the end of the main text of this report.

**Definitions of acoustical terms and symbols used in the guidelines are provided in Appendix A. In this report, decibels are always assumed to be A-weighted unless designated otherwise.

adverse noise levels. In addition, a traditional, non-quantitative description of the noise impact is encouraged, either as a supplement to these numerical descriptions, or, in unusual cases, as the sole analysis of the noise impacts.

The preparation of a noise impact analysis proceeds through several distinct steps to arrive at these descriptions of the noise impact, which are then used in the decision-making process (Figure 1). The methods proposed for use in each of these steps (Table 1) are based, in part, on the work and the progress achieved over the last few years by interagency committees, on the recommendations of the National Academy of Sciences-National Research Council, and on other scientific findings.

For measurement of the noise environment, use of the A-weighted day-night sound level (L_{dn}), officially adopted by several government agencies (see Appendix B, Table B1) since publication of the Environmental Protection Agency's "Levels Document" [2], is recommended as the primary measure of general audible noise. L_{dn} has been recommended as an environmental noise descriptor for purposes of land use compatibility planning by an interagency task force on this subject [3], and by the American National Standards Institute [4]. Circumstances calling for the use of short-term measures of general audible noise are also discussed. A modification of the day-night sound level for impulse noise is based on a report of a National Academy of Sciences, Committee on Hearing, Bioacoustics and Biomechanics (CHABA) [5]. Measures to be used for infrasound, ultrasound, and vibration are also described in these guidelines.

The quantification methods recommended for impact assessment in these guidelines are further developments of the Fractional Impact Methodology used by EPA for assessing the health and welfare effects of a noise environment.

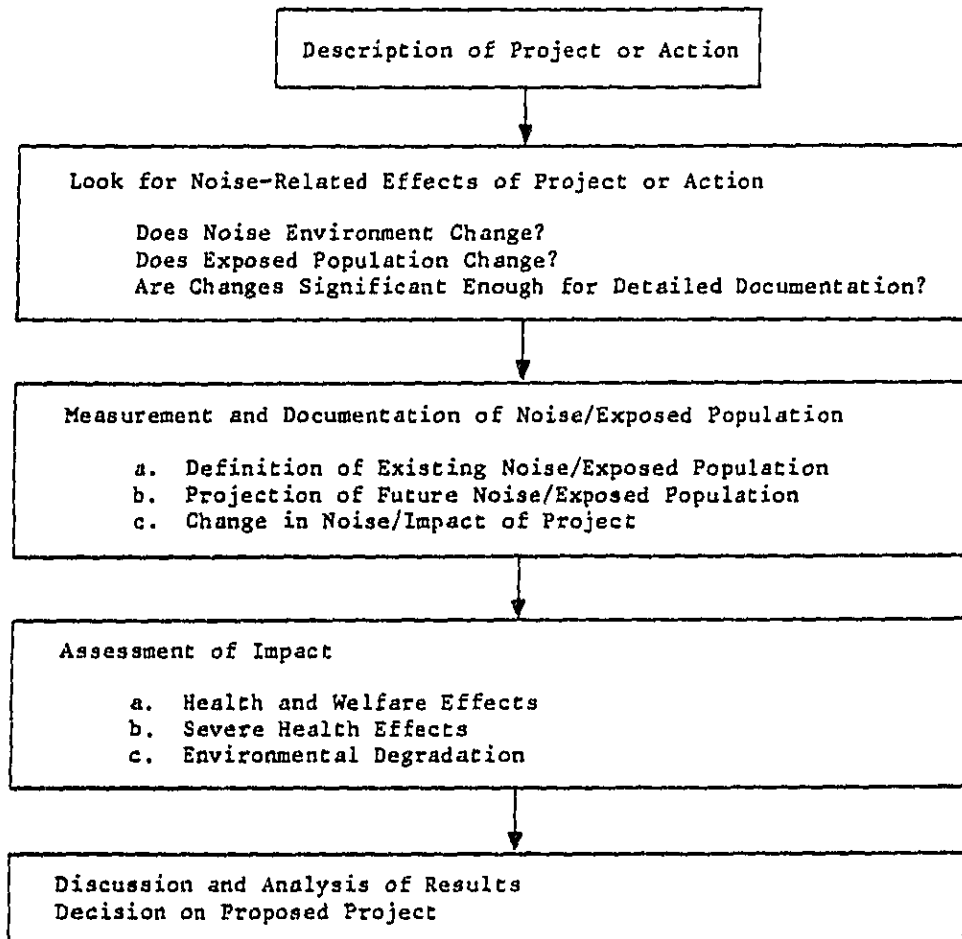

Figure 1. PREPARATION OF A NOISE IMPACT ANALYSIS

TABLE 1. SUMMARY OF METHODS FOR NOISE IMPACT ANALYSIS

TYPE OF ENVIRONMENT		TYPE OF CRITERIA	RECOMMENDED NOISE MEASURE	SCREENING LEVELS	ASSESSMENT METHODOLOGY
GENERAL AUDIBLE NOISES		POTENTIAL FOR LOSS OF HEARING	8-HOUR AVERAGE SOUND LEVEL OR 24-HOUR AVERAGE SOUND LEVEL	$L_{dn} = 75 \text{ dB}$	HEARING-LOSS-WEIGHTED POPULATION, HWP
		GENERAL ADVERSE EFFECTS	DAY-NIGHT SOUND LEVEL	PROJECT LEVELS HIGHER THAN 10 dB BELOW THE EXISTING LEVELS	SOUND-LEVEL-WEIGHTED POPULATION, LWP
		ENVIRONMENTAL DEGRADATION			TABLES AND DESCRIPTION ONLY
SPECIAL NOISES	HIGH ENERGY IMPULSE NOISE	STRUCTURAL DAMAGE	PEAK PRESSURE	EMPIRICAL FORMULAS	TABLES AND DESCRIPTION ONLY
			PEAK ACCELERATION	1 m/sec^2 INSIDE	
		ANNOYANCE DUE TO AUDITORY STIMULATION AND BUILDING VIBRATION	DAY-NIGHT SOUND LEVEL USING C-WEIGHTED SOUND EXPOSURE LEVEL, L_{SC} , FOR IMPULSES	L_{SC} OF 80 dB FOR DAYTIME, OR 70 dB FOR NIGHTTIME	SOUND-LEVEL-WEIGHTED POPULATION, LWP
	INFRASOUND	ANNOYANCE AND PHYSIOLOGICAL	$0.1 \text{ Hz to } 20 \text{ Hz}$ } $20 \text{ kHz to } 100 \text{ kHz}$ } MAX-SOUND PRESSURE LEVEL	$0.1 \text{ Hz to } 5 \text{ Hz: } 120 \text{ dB}$ $5 \text{ Hz to } 20 \text{ Hz: } 120.30 \text{ LOG } \frac{F}{5}$ 105 dB	DISCUSSION OF POSSIBLE EFFECTS. NO TABULATION MADE
ULTRASOUND					
VIBRATION		STRUCTURAL DAMAGE	PEAK ACCELERATION (WEIGHTED)	1 m/sec^2 FOR MOST STRUCTURES 0.5 m/sec^2 FOR SENSITIVE STRUCTURES 0.05 m/sec^2 FOR CERTAIN ANCIENT MONUMENTS	TABLES AND DESCRIPTIONS ONLY
		ANNOYANCE AND COMPLAINTS	RMS ACCELERATION (WEIGHTED) VERSUS TIME OF EXPOSURE	0.0030 m/sec^2 , OR HIGHER DEPENDING ON TIME OF DAY AND TYPE OF PLACE	VIBRATION-WEIGHTED POPULATION, VWP

For the general adverse response to noise in the 55 to 75 dB (L_{dn}) range, the function is based on data presented by Schultz in a recent review paper [6]. Similar impact assessment methods are proposed in these guidelines for quantifying the following: the potential for loss of hearing at 24-hour equivalent sound levels in excess of 70 decibels; the general adverse response to impulse noise; and the complaints caused by vibration. For general audible noise in rural and wilderness areas, and for infrasound and ultrasound, qualitative rather than quantification methods are suggested.

The measures and methods listed in Table 1 and described in this report are simplifications, and the recommendation for their use is not intended to discourage more rigorous approaches. However, to provide a common framework for comparison of different environmental noise assessments (conducted by different persons in different parts of the country), it is strongly recommended that the methods of these guidelines also be used along with any other additional approach.

1.3 Structure of the guidelines

Three principal types of noise and vibration environments are considered: general audible noise; special noises; and vibration. General audible noise is noise as commonly encountered in our everyday living environment. It can be adequately described by either the equivalent A-weighted sound level (L_{eq}) or its variation that includes a nighttime weighting, the day-night sound level (L_{dn}). For most practical cases this type of noise measure will adequately describe the noise environment, and much of the document concerns the evaluation of general audible noise. Not all noises can be adequately evaluated by average sound levels, however. Examples of such special noises are infrasound (frequency range of 0.1 to 20 Hz), ultrasound (frequency range

above 20 kHz), certain types of impulse noises (such as blasts and sonic booms), and sounds that convey more information than random noise sources with comparable average sound levels (such as voices, warning signals, or barking dogs). Procedures are also included for evaluating the impact of vibration on man. While the main reason for their inclusion here is to account for vibration generated by airborne noise, the impact of certain types of vibration can be assessed whether the transmission paths are airborne or structureborne.

There is a separate chapter for each of the three principal types of environment. Each chapter covers four topics: the appropriate physical measurement for that type of noise; methods for determining the existing levels and for predicting the levels for the proposed project; human noise exposure criteria; and procedures for quantifying the impact, usually in terms of those criteria. All of the information necessary to deal with one type of noise environment is thus in one place, to minimize the effort required by a user to follow these guidelines.

1.3.1 Preliminaries

The logic of the structure of these guidelines has been set out in a combined flow chart and worksheet (Figure 2), to provide guidance for using this report and for carrying out the various parts of the noise impact analysis. There are four principal branches in the flow chart (labeled A, B, C and D) to be followed, depending on the nature of the proposed project and its potential impact. There are exit points along each of the branches, at which the analysis for that branch may stop without the need for any further analysis, since it is clear by then that there is no significant noise impact with respect to the concern on that branch. At the right-hand edge of

NOTE: NUMBERS IN PARENTHESES REFER TO THE APPROPRIATE SECTION OF THESE GUIDELINES.

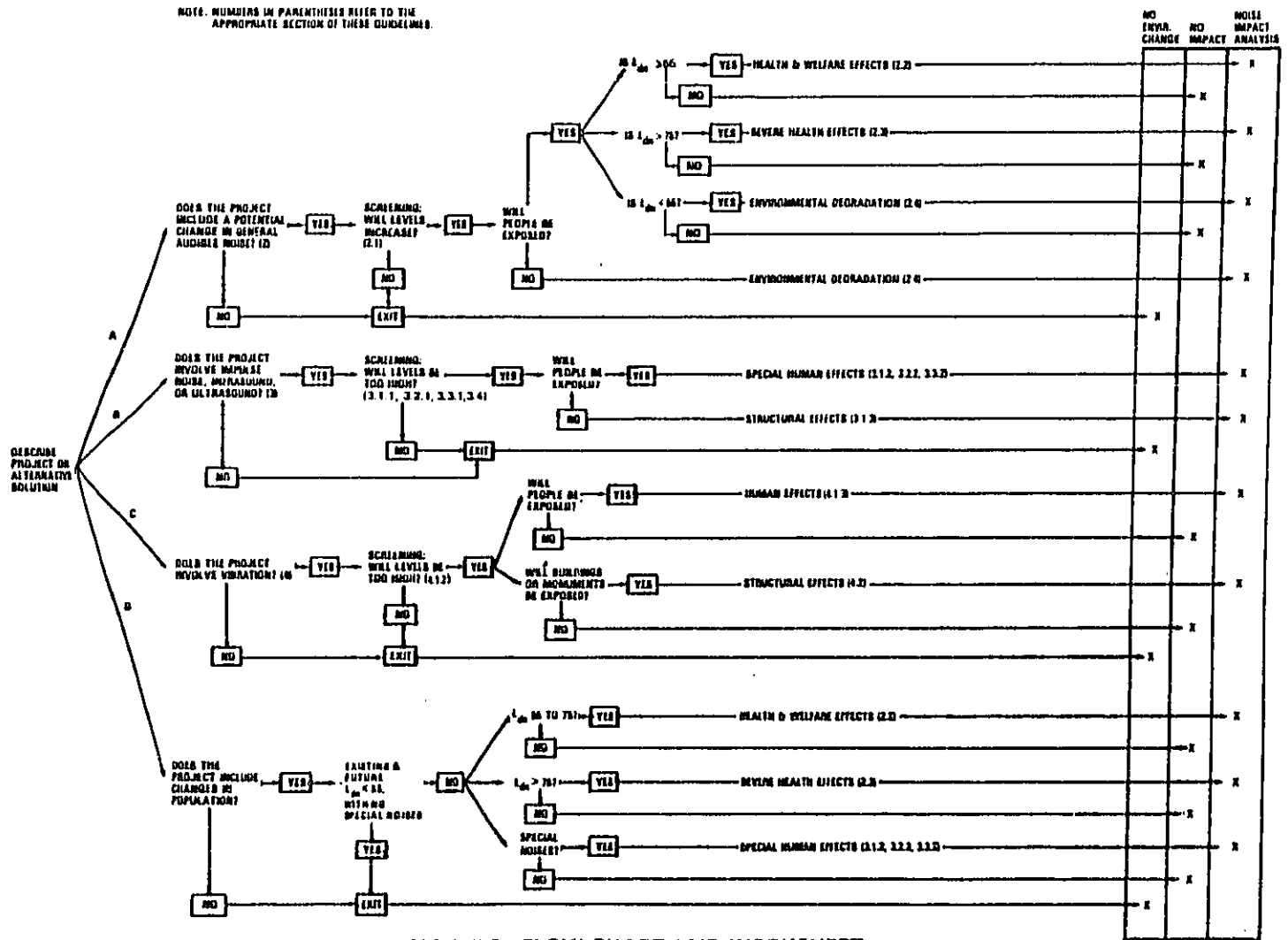

FIGURE 2. FLOW CHART AND WORKSHEET

the flow chart there are three columns that can be checked to indicate the outcome of the analysis at each branch point. When this flow chart is used as a worksheet, these columns summarize the noise impact analysis for the project, showing the stages at which exit points occurred, and calling attention to aspects of the noise impact receiving explicit evaluation according to the methods of Chapters 2, 3, and 4.

Usually, there will be not just one version of the proposed project, but a number of alternative proposals. Each of these alternatives must be analyzed for noise impacts. There will thus be a flow chart worked through for each of the alternative schemes. Each of the worksheets, by its summary columns of checked boxes, will indicate what aspects of the noise impact of that alternative received explicit consideration. A comparison of these columns will facilitate choosing the project alternative with the least noise impact on the environment.

1.3.1.1 Flow chart

The following discussion of the use of the flow chart provides a brief explanation of each of the branches. (The section of this report containing the more detailed discussion is indicated in parentheses on the flow chart.)

The first step is to provide a general description of the proposed project, including those aspects that are expected to contribute to noise impact. The expected noise impact may be either adverse, if the noise environment would be worsened by the project, or beneficial, if the environment would be improved. Both the short term and long term effects expected from the project should be described. For example, the construction of a new airport or highway in a sparsely settled region would have as its initial impact

an increase in noise that would affect relatively few people. However, the new facility will attract new people and business which will increase the nearby population density, unless proper land use planning and implementation occur. Thus the ultimate noise impact may be significantly greater than that projected on the basis of the initial effect alone. To evaluate an action over time, it is suggested that, if feasible, a time interval of 20 years be used, unless the project will be in existence less than 20 years, in which case the project lifespan should be used. Thus, the initial impact and the expected impact after 20 years should both be evaluated. To present a complete picture, the impact after 5, 10, and 15 years might also be presented. When comparing the impact between projects or alternatives or when assessing cost-effectiveness, the average impact over a 20 year period may be used.

The first branch point in the flow chart occurs after the potential noise impacts of the proposed project have been described. At branch points such as this, each of the available branches (labeled A, B, C and D) should be taken and followed through to the appropriate indicators in the righthand columns. At each of the question points following each branch, if the project will entail no change at all, the 'NO' answer will be followed to 'EXIT', and the analysis for that branch is complete. In that case, check the box at the right-hand side of the page under 'No environmental change'. If exit points have been found for each of the branches A, B, C, and D, the noise analysis need not proceed further: four check marks will be in the column labeled "No environmental change" at the right of the page and the noise analysis is finished. The environmental impact assessment on noise will simply state this fact. Otherwise, the analysis continues in those branches in which no exit point has been found.

DEPT ENVIRONMENTAL

1.3.2 General audible noise

If on the first branch the project was found to include a potential change in general audible noise, chapter 2 is appropriate, describing how to identify and quantify the noise impacts for such an environment. The analysis begins with the screening step, to determine if the potential change is large enough to pursue in a detailed analysis (section 2.1). If it is not, the 'NO' response is again followed to 'EXIT' and the analysis for this branch is complete.*

If the potential change is large enough to warrant further analysis, the next question is whether people will be exposed to the noise from the project. If the answer is 'YES', there are three branches to follow, depending on the level of noise resulting from the project. The first branch deals with the range bounded roughly by L_{dn} values of 55 dB and 75 dB, in which general health and welfare criteria are the impacts of interest (section 2.2). The second branch concerns projects which include noise levels above 75 dB (L_{dn}). Where this occurs, severe health effects due to noise should be considered (section 2.3). The third branch is for projects which result in levels less than 55 dB (L_{dn}). Although these are levels below which adverse noise effects generally do not occur, environmental degradation is of concern, and should be discussed (section 2.4). For each of these three ranges of general audible noise, the section identified provides a discussion of the human exposure criteria, and methods for quantifying the impact in terms of these

*The flowchart and worksheet is designed primarily for those cases where the noise (or vibration) impact is expected to be adverse, that is, the noise environment is anticipated to be worsened by the project. If the project entails a reduction in noise, thus improving the environment, the flowchart and worksheet can still be used as a guide to carrying out any noise assessment that may be desired to ascertain the degree of improvement. See the discussion in section 1.4.1.

criteria. It should be pointed out that at this branching point, at least one of the three sound level ranges must lead to the requirement for a noise impact analysis, and possibly more than one branch will do so. That is, these categories are exhaustive (i.e., they cover all the possibilities), but they are not mutually exclusive (i.e., more than one can occur).

Even if people do not normally live or work in the area exposed to the new noise levels, environmental degradation is still of concern. As such, this is difficult to quantify but it should be discussed, preferably in terms of the principal uses made of the affected area (e.g., urban recreation, wilderness recreation, wildlife).

1.3.3 Special noises

If the project is found to involve special noises, namely impulse noise, infrasound, ultrasound, or sounds with negative information content, it is necessary to follow branch B further (chapter 3). The screening step verifies that the levels involved are high enough to warrant an analysis.* These levels are discussed separately for each type of special noise: impulse noise in section 3.1.1; infrasound in 3.2.1; ultrasound in 3.3.1; and noises with information content in section 3.4. If people are exposed to one or more of these special noises, the second part of the appropriate section of chapter 3 is available, describing procedures to be used to discuss and quantify the impacts. For impulse noise, there is also the possibility of structural damage (section 3.1.3).

This section of the flow chart is obviously somewhat simplified. If it were drawn in full detail, there would be a branch such as this for each one of the four special noises. Thus one should repeat this branch four times.

*See footnote on page 12.

The reason for the simplification is that in most (but not all) cases encountered, no more than one type of special noise will generally be involved.

1.3.4 Vibration

Branch C is followed if the project involves vibration (chapter 4). Again, there is a screening step to allow an 'EXIT' to 'NO ENVIRONMENTAL CHANGE' if the levels are low enough (section 4.1.2).* If the levels are higher than the cut-off, there are two branches to be pursued, the first if people are exposed (section 4.1.3), and the second if buildings or monuments are exposed (section 4.2). Thus for vibration there are both human and structural criteria to be considered in assessing potential impact.

1.3.5 Potential changes in population

Some projects entail exposing new populations to existing noise levels, for example the construction of a housing development in an area adjacent to a major roadway. Branch D of Figure 2 describes the procedures to be followed in such a situation. If the noise levels from existing sources are presently below 55 dB (L_{dn}), and are expected to remain this low in the future, then there is 'NO IMPACT', and no further analysis is required on this branch (as long as there are also no special noises encountered). It should be noted, however, that higher density development (whether residential, industrial, or commercial) usually brings with it increasing noise levels, such that it is unlikely that sound levels after project completion will be as low as they are at present. This 'EXIT' is unlikely to be realistic for any major development. If the noise levels are not below 55 dB (L_{dn}), or if special noises are present, the analysis follows the same steps as did

*See footnote on page 12.

branch A, when new noises affected existing populations (sections 2.2, 2.3, and chapter 3).

1.3.6 Examples

The following examples are presented to illustrate which of the major branch(es) of the flow chart to use for various projects:

- (1) A project that entails a change in land use may cause only a change in the existing noise in an area, so only Branch A or B would be followed; on the other hand, it may only involve relocation of some of the population, in which case only Branch D would be followed. If the project is expected to cause (or diminish) vibration, Branch C would be followed. Most land use changes, however, will involve a combination of A, B, C, and D.
- (2) A project involving the installation of new equipment, or the replacement of old equipment, is likely to require analysis of only branches A, B, and/or C, since no population shift is likely to be involved.
- (3) A project that consists of a new regulation, or a change in an existing regulation, might follow either A, B, or D (see discussion in section 1.4.1). For example, a new regulation reducing the noise output of heavy trucks would change the noise along a highway, and thus Branch A should be followed. On the other hand, a change in the noise policy of a federal, state, or local housing authority may alter the distribution of future dwellings among neighborhoods with different levels of existing noise; such a regulation would change the population exposed to noise without affecting the noise anywhere, and hence would warrant analysis along Branch D.

- (4) A new airport, whose primary effect would be increased noise levels in the neighborhood (Branch A), might impact only presently undeveloped land that could be spoiled for later residential development by the airport noise. The future magnitude of the impact would be quite different for a prospective airport where land is purchased around the proposed site for controlled leasing to non-noise-sensitive activities as compared to one where such precaution was not taken.
- (5) A project that causes a change in the interior noise of aircraft cabins or a change in the noise insulation of automobile bodies would be analyzed on a path along Branch A, since it changes the noise environment in existing spaces with a definable existing population.

1.4 Other considerations

The preceding summary of the structure of these guidelines, and of the flow chart representing that structure, is written to deal with a proposed project which will increase noise levels, or in which more people are exposed to existing noise levels. These are not the only types of projects for which noise impacts should be considered. This section describes an additional situation in which noise impacts are a concern--projects aimed at reducing noise levels. The section also discusses two topics which are relevant to all three of the chapters which follow: shortened analysis procedures for temporary projects; and the treatment of uncertainties encountered in the analysis.

1.4.1 Projects which reduce noise

Two of the examples of proposed actions with noise-related impacts described on page 1 deal with the reduction of noise. If an action is proposed in order to reduce noise-related impacts, it is immediately obvious

that an analysis of those impacts is called for. In most cases it is equally obvious what kinds of impacts are of interest (e.g., general health and welfare impacts). Hence the flowchart and worksheet are not really needed as an aid to identifying the area of concern. Instead, one may simply turn to the appropriate sections of these guidelines for a discussion of useful procedures for quantifying noise impacts. In other words, the procedures (described subsequently) apply equally well to projects which reduce noise as they do to projects which increase noise. The summary of those procedures (described previously) is written only in terms of projects which increase noise.

1.4.2 Temporary projects

At this stage of a noise impact analysis, the specific types of noise impact requiring detailed documentation will have been identified. This will have been accomplished either through the use of the worksheet (Figure 2), or by the fact that the action is intended to reduce noise impacts. The next question to address is how far into the future the analysis should go. Earlier, it was suggested that either the project duration or twenty years, whichever is less, should be considered (section 1.3.1). This means that not only noise levels, but also affected populations, need to be predicted over the time period of interest. The impacts to consider are not merely the immediate ones, but long-term ones as well.

Documentation of the impact for temporary projects is simplified by the fact that population prediction is unnecessary; existing population or land use information is sufficient. In this context, temporary is taken to mean less than roughly two years duration. Beyond that length of time, significant population changes may take place in an area, so that population forecasts

become important. This would be true even for construction projects of longer duration, which might be in place for 5-10 years.

1.4.3 Uncertainties in the analysis

There will almost always be areas of uncertainty in the noise impact analysis, usually because of the unavailability of needed factual information. For example, the projected future traffic volume for a proposed freeway may be uncertain; the noise of a not-yet-built device may be only approximately known; or the population estimated to be exposed to various sound levels from the project may be subject to error. In all cases, a discussion of the probable source and degree of these uncertainties should be included in the analysis. Perhaps the most suitable approach for this purpose is to take the upper and lower bound for each of the uncertain quantities that enter into the analysis, and group the "most favorable" and "least favorable" bounds of these quantities together to arrive at two estimates of the environmental noise impact: the best and worst cases that together bracket the range of likely actual results of proceeding with the proposed project.

CHAPTER 2
GENERAL AUDIBLE NOISE

This chapter describes procedures to be followed for analyzing and documenting the noise-related impacts of proposed projects which affect or are affected by general audible noise. The first section outlines a screening procedure for determining whether the expected noise levels of the proposed project are high enough to warrant detailed analysis. As part of that discussion, appropriate noise measures are identified, and methods for estimating and predicting them are indicated. The second section discusses the general health and welfare effects of noise on people, which serve as the criteria for evaluation of noise in most urban and suburban settings. It also provides a procedure which can be used to summarize these effects with a single number impact descriptor. The third section discusses the severe health effects which can be caused by higher levels of noise, and suggests a single number impact descriptor for these. The fourth section discusses procedures to follow for projects which will have reasonably low noise levels, but which are located in very quiet areas--that is, projects for which environmental degradation is the primary concern. Simplifications of these analysis procedures which can be used for temporary projects are described in the fifth section. The final section contains a sample application of the procedures, including samples of the types of tabulation which are recommended.

The criteria used in this chapter are not to be considered all-inclusive; additional information should be used depending on the scope and magnitude of the environmental change. The EPA Criteria and Levels documents [7,2] can be consulted as additional reference sources as well as any other applicable information.

2.1 Basic screening procedures

Some proposed projects will obviously cause severe noise impact on their surroundings, others may obviously be so quiet as not to change the noise environment at all. In the first case there is no doubt that a full analysis of the noise impact is required; in the second case one would simply state, with minimal documentation, that no impact is expected. About many projects, however, there will be a question as to whether their noise impact is significant enough to warrant a full noise impact analysis. This section offers a screening test to determine how extensive a noise analysis is needed.

Figure 3 presents a screening diagram for use in determining whether a full impact analysis is needed. The diagram is based on a comparison of the existing noise environment and the noise environment due to the proposed project alone.* This comparison should normally take place at the noise sensitive location(s) in closest proximity to the proposed project.** So long as the expected yearly L_{dn} (see section 2.1.1 for explanation of L_{dn}) from the project is lower than 10 dB below the existing yearly L_{dn} , the project is screened out, i.e., no further analysis is required because the change in

*The meaning of "project alone" is clear when an entirely new facility is to be built. But what about the expansion of an existing facility? In such cases, "project alone" should be considered to be the total expanded facility or project. For example, if the project is the widening of an existing highway from two to six lanes, future noise levels from the "project alone" would be the noise from the six-lane highway, not just the noise from the additional four lanes. That is, the "project alone" is the new six lane highway.

**There are some exceptions to this rule. If it is known that the greatest noise impact will occur at a noise sensitive location farther away, the comparison should take place at that point. An example would be a close-in area protected from the noise by natural terrain, relative to an unprotected point farther away. If the latter location receives the greatest impact, the comparison should take place at that point.

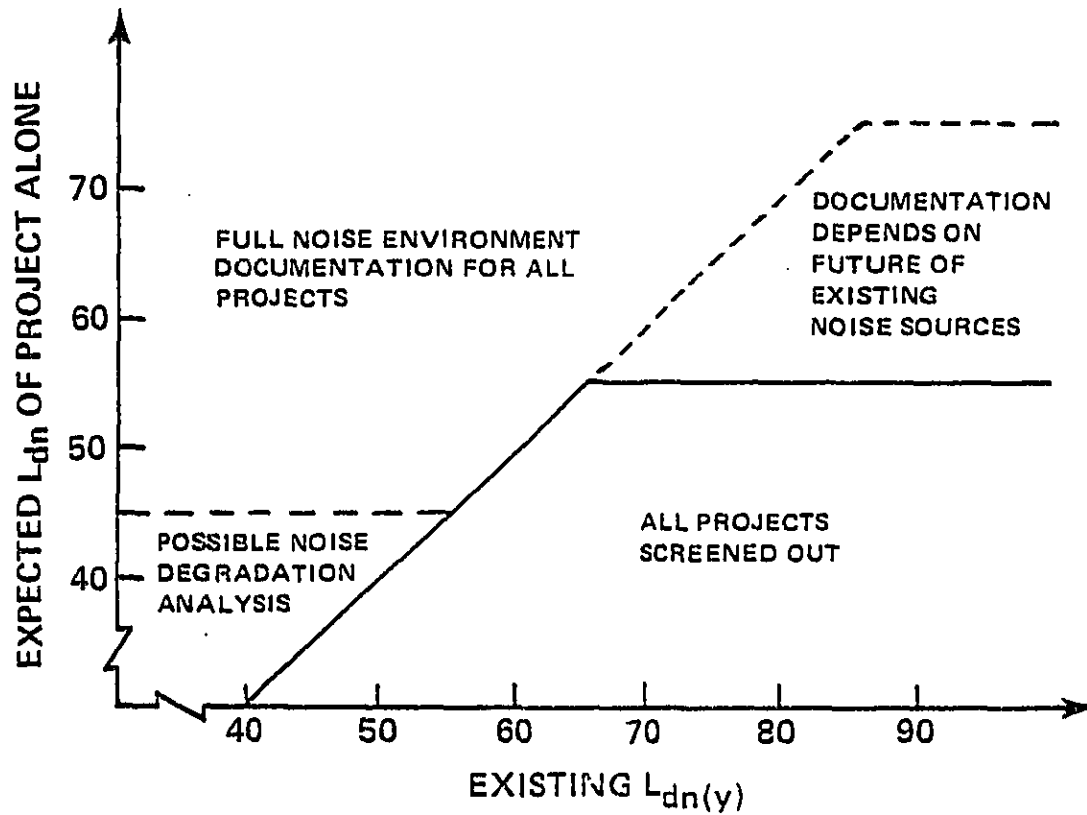

FIGURE 3. SCREENING DIAGRAM

the environment is not significant.* The rationale for the location of the screening line in Figure 3 is that for any project which is not screened out, the total environmental noise level after project completion will be increased from the existing levels. For example, if a project alone is expected to produce the same level of noise as the existing yearly L_{dn} , then post-project total environmental noise will be increased by 3 dB. If the difference obtained by subtracting the project alone noise levels from the existing levels is greater than 10 dB, the post-project total noise level will increase by less than 0.5 dB, which rounds off to a zero increase.

For any new project in which the expected L_{dn} is greater than 55 dB, the probability of significant noise reductions of some of the existing sources should be considered. If the existing levels are high because of one major source which is likely to be quieted in the future, then the proposed project should not be screened out; further analysis is needed since, in the future, the proposed project could become relatively more dominant than expected on the basis of existing noise levels. If the existing levels are unlikely to be reduced, then the project can be screened out.** However, even if no reductions are likely an impact analysis can still be carried out, and in many instances is strongly encouraged, based on idealized or hoped for future noise levels for the area. In other words, noise impact analysis is recommended for noisy projects even if they are in already noisy areas.

*If the project is temporary with a duration of less than one year, expected yearly L_{dn} should not be used. Rather, it is more appropriate to use the day-night sound level averaged over the actual duration of the project (see Section 2.5). In any case, existing yearly L_{dn} is always used.

**Even if existing levels are unlikely to be reduced, a further analysis may still be needed in cases where the project noise differs significantly in quality or temporal character from existing sources.

The diagonal line in Figure 3 continues as the indicator of screened-out projects to very low noise levels. For proposed projects which are above this line, but produce levels below $L_{dn} = 45$ dB, a modified form of noise impact documentation is suggested. The modification is needed in part because of the lack of data on the effects of very low level noise. Such low levels are in fact extremely rare, if indeed they ever occur. Even on the north rim of the Grand Canyon, the L_{dn} was found to be close to 44 dB, due to bird, animal, and insect noises [8]. Hence it is not expected that situations in the lower left portion of the diagram will be encountered often, and the diagram has been truncated accordingly.

2.1.1 Measures for the description of general audible noise

The primary measure for describing general audible noise is the day-night sound level, symbolized as L_{dn} . The unit for L_{dn} is the decibel. The day-night sound level is a 24-hour equivalent sound level in which nighttime noise levels occurring between 10:00 p.m. and 7:00 a.m are increased by 10 dB before calculation of the 24-hour value. Equivalent sound level is numerically equal to the value of a steady sound level that would convey the same mean-square A-weighted sound pressure level as does the actual time-varying sound in the same time period. Equivalent sound level is also called average sound level.

Long term environmental impact is evaluated by the yearly day-night sound level, symbolized as $L_{dn}(y)$. The yearly average is recommended on the grounds that the noise metric used should be one which reflects any change in the noise environment, and that this should be done consistently for different sources. Yearly day-night sound level is analogous to the traffic engineering concept of annual average daily traffic. In other words, it is meant to

represent levels measured under average conditions, or, if conditions vary during the year, weighted averages of levels at the different times of year.

In some instances, a rough approximation to annual average conditions or noise levels will be sufficient; in others, it will be necessary to be more precise. For example, noise levels for some airports are reported for an average busy day, rather than an annual average. If the project under analysis is land-use development, it is quite reasonable to use such existing noise information, even though it is not exactly the annual average. The error in the data is small enough that the cost of a more exact estimate of the annual average is not warranted. On the other hand, if the project being analyzed involves a change in airport use (for example Sunday flights when there were previously none) the noise level typical of an average busy day may lead to nonsensical results. (The busy-day level would be reduced, in the example, if the aircraft noise on Sunday was less than the average on other busy days--even though over the year more noise was being produced because of the added operations.) Approximations for the annual average L_{dn} can be very useful shortcuts, but need to be applied with careful judgment.

Day-night sound level is the primary measure of general audible noise, and is appropriate for noise environments that affect a community over an entire 24-hour day. There are two kinds of situations where such a measure is not appropriate, however. The first kind consists of those situations in which it is desirable to assess the effect of a noise environment on an activity of less than 24-hour duration. An example is the effect of noise on speech communication in classrooms or in offices. In these situations it is useful to consider the equivalent sound level, $L_{eq}(T)$, over the time period of interest (T), for example one hour or eight hours, ($L_{eq}(1)$ or $L_{eq}(8)$).

The second kind of situation covers those in which the noise is not present for enough of the day to greatly affect the L_{dn} reading, but is still subjectively judged as intrusive and disruptive when it is present. Examples of such noise sources may include motorcycle passbys, trains, and specific aircraft flyovers. The appropriate sound measure for such an event is the cumulated sound produced by the single event, the A-weighted sound exposure level, L_5 . It is a measure of accumulated, not average, sound energy.

Precise mathematical descriptions of all these measures are provided in Appendix A. All are expressed in A-weighted decibels; the reference sound pressure is 20 micropascals.

2.1.2 Determining the yearly day-night sound level

For the screening procedure, two yearly L_{dn} values need to be determined: the existing levels; and the levels expected to be caused by the proposed project. In addition, for the impact assessment it will be necessary to estimate the future yearly L_{dn} values in the area if the project is not constructed. (The total post-project noise level can then be calculated as the (logarithmic) sum of the project levels and the future levels in the absence of the project.*)

Determining $L_{dn}(y)$ by direct measurement. To establish the existing noise exposure accurately, field measurements are oftentimes the preferred approach. Unfortunately, such measurements can be expensive and time-consuming. Nonetheless, measurements may be warranted. For example, if the present average sound levels are already high, so that the noise impact of a new

*See Appendix E for examples on how to calculate logarithmic sums of project levels and future levels in the absence of the project.

project will not be much greater, or may be even less than the impact from the existing noise environment, it may behoove the applicant to conduct a measurement program, so as to predict the noise impact more accurately.

When an existing noise environment is to be determined by direct measurement, it will be necessary to make measurements at a number of locations sufficient to establish a credible baseline for estimating total impact. The number of measurement locations and their geographic disposition will depend on the spatial extent of the impact expected to be produced by the project.

Measurement periods and the time intervals between them should be determined by the characteristics of the existing noise, in order to obtain a reliable estimate of yearly L_{dn} . If the existing noise is expected to be substantially the same from day to day, measurements during a single typical 24-hour period may be adequate. Locations where the noise is caused primarily by well-established motor vehicle traffic patterns are an example. In other situations where strong daily, weekly, monthly, or seasonal effects occur, it may be necessary to measure for a number of different daily periods suitably chosen to account properly for these variations. In some particular situations, the variations may be large enough to make measurement practically infeasible. A case in point might be in the vicinity of an airport with more than one runway which has no on-going noise monitoring program.

The most reliable temporal data are obtained by techniques that approach continuous measurement of the sound level over the time period in question. In some instances it may be reasonable to obtain or sample measurements over only fractions of the total time--e.g., several minutes per hour. However, any measurement method used to approximate continuous measurement of L_{dn} should be justified by adequate technical reasons and data to show the

accuracy of the procedure when applied to the specific noise sources being described.

If field measurements are undertaken, they should be conducted in accordance with accepted procedures [9].

Determining $L_{dn}(y)$ by the use of engineering prediction models. Several kinds of noise have been extensively studied, particularly the noise of transportation, and procedures have been developed for calculating day-night sound levels based on the type of noise source and operational considerations. Procedures for estimating the noise of specific sources such as roadways [10,11,12,13] and aircraft near airports [13,14,15] are available and may be easily adopted for those situations in which the existing noise environment is dominated by a major noise source. A partial bibliography of some of these engineering prediction models for roadways, aircraft, transmission lines, outdoor recreational sources, and high-energy impulsive noise is included at the end of Appendix E.

Determining $L_{dn}(y)$ from the population density. Where no dominant source of this nature is present, the existing noise environment may be considered to be caused primarily by local automotive traffic noise. For these instances, the day-night sound level may be estimated on the basis of population density in accordance with the values listed in Table 2. For convenience, the population density values in Table 2 are listed in terms of both persons per square mile, and persons per square kilometer. The data contained in Table 2 are based on the equation:

$$L_{dn} = 10 \log \rho + 22 \text{ dB} \qquad \text{Eqn. 1}$$

where ρ is the population density in persons per square mile. This relationship was derived from measurements at 130 urban locations [16]. The equation

has a standard error of 4 dB, which means that the 95 percent confidence interval around the estimate is roughly ± 8 dB. The reliability of the relationship is approximated by the correlation coefficient of 0.723 between L_{dn} and the log of the population density over the 130 data points. This can be interpreted as indicating that the log of the population density explains 52 percent of the variation in L_{dn} . This amount of uncertainty about the true L_{dn} may or may not be acceptable for a given project. If it is not, measurements or source-based predictions are recommended.

The levels shown in the table represent average values for residential areas that are not in the vicinity of an especially noisy existing source such as an airport, a freeway, a railroad, or a switching yard. If such a noise source exists, its contribution to the existing L_{dn} should be estimated separately, and then combined with the level given in Table 2. The values in the table are representative of space average values over areas of the order of 1 km^2 (0.4 sq. mile), or larger, for typical urban conditions.

For purposes of estimating the existing noise in relation to permanent changes in areas with population density greater than 20,000 persons/sq. mile, the day-night sound level should be taken as 65 dB. Higher estimates of the background noise by the use of equation 1 require specific justification such as direct measurements or detailed calculations based on existing noise sources. The reason for this suggestion is to avoid obtaining low numbers for the impact of noisy projects in heavily populated areas. This is in line with the discussion of accounting for existing noisy areas when using the screening diagram. Particularly when an area is noisy because of high population density it is important to consider very carefully any project which will add to the noise in the area, and therefore not to initially screen it out by using high estimates of existing levels.

TABLE 2

YEARLY DAY-NIGHT SOUND LEVEL AS ESTIMATED BY POPULATION DENSITY
(To be used only for residential neighborhoods where
there is no well-defined source of noise)

<u>Description</u>	<u>Population Density (People/Sq. Mi.)</u>	<u>L_{dn} in dB</u>	<u>Population Density (People/Sq.km.)</u>
Rural (undeveloped)	20	35	8
Rural (partially developed)	60	40	23
Quiet Suburban	200	45	77
Normal Suburban	600	50	232
Urban	2000	55	772
Noisy Urban	6000	60	2317
Very Noisy Urban	20000	65	7722

Note: L_{dn} estimates for population densities lower than 1000 persons/sq. mi. are extrapolations.

With respect to problems of estimation in rural areas, there simply is not enough known about noise levels in such areas, since measurements such as those used to calculate equation 1 are routinely conducted only in the absence of wind, rain, and other natural sounds. Values obtained using equation 1 (or Table 2) that extrapolate beyond the data base should be used with caution. Whenever possible, measurement of existing levels is recommended.

Estimation of future noise levels with and without the proposed project.

Most of these procedures which have been identified for estimating existing noise levels can also be used, as appropriate, to estimate the noise levels due to the proposed action or project. Prediction procedures, approved by various federal agencies, are available for a number of typical situations, including aircraft, motor vehicles, railroads, construction equipment and other noise sources. In some instances those procedures do not provide predictions for L_{dn}. In those cases, the conversion equations provided in Appendix B, Table B2, can be used to estimate the L_{dn} values, in order to

use the information in these guidelines to express the impact of the noise on people.

If prediction techniques are not available for a particular project, for example a specific industrial installation, measurement of noise levels at a similar existing installation is appropriate, although an engineering description should be included of the reasons for anticipating such similarities in a new installation. Likewise, where the introduction of a new noise source is anticipated and neither an existing approved procedure nor a similar installation is available, an engineering description of the procedure employed to estimate noise emissions should be provided in adequate detail for technical evaluation of its acceptability.

For predicting future noise levels in the absence of the proposed project, the available methods are (1) extrapolation of existing levels to the future, (2) the use of source-specific prediction techniques, or (3) the use of equation 1.

2.1.3 Determining the population affected by the noise of the proposed project

For each of the alternatives that involves the introduction of some form of a new noise source, the affected population is defined as that population experiencing sound levels produced by the new noise source above a specified yearly L_{dn} . This will be called the base yearly L_{dn} , or base $L_{dn}(y)$. The base yearly L_{dn} may be determined by references to existing yearly L_{dn} contours in the area of interest (See section 2.1.2). Consistency with the screening diagram requires the consideration of impacts whenever the overall post-project level is greater than the pre-project level, that is, when the project alone L_{dn} is greater than pre-project L_{dn} less 10 dB. Thus, the base L_{dn} will usually be 10 dB lower than the existing (pre-project) yearly

L_{dn} . For example, if the existing yearly L_{dn} is 60 dB, it is suggested to start with a base $L_{dn}(y)$ of 50 dB, if possible, in order to determine the number of people affected by the project noise. In some instances, however, it will not be feasible to predict project noise levels to such low values. (An example of such an instance would be around commercial airports, where existing prediction techniques are not particularly reliable below an L_{dn} of 65 dB, due to lack of information about aircraft flight track usage.) In such cases, it is still imperative to consider as large a range of levels as is feasible. A difference of 20 dB between the maximum $L_{dn}(y)$ for the project and the base $L_{dn}(y)$ is a good range to attempt to achieve, providing that it results in a base $L_{dn}(y)$ of 55 dB or less, if feasible, since $L_{dn} = 55$ dB has been identified as a point below which significant adverse noise effects generally do not occur [2]. If the procedure results in a higher $L_{dn}(y)$, a base level of 55 dB should be chosen.

When several alternatives are compared, a common base area or base population should be used for all alternatives. In such cases the base area or population for all alternatives will be the largest area or population affected by any alternative. In other words, the base population will be determined by the project alternative which has the highest yearly L_{dn} in a given location in a given year. The reason for requiring a common base is that several of the measures of relative impact, to be discussed subsequently, will be meaningless if the total number of people over which they are calculated changes from one alternative to the next. The base population, therefore, should include all people who are affected by the noisiest alternative. As a consequence, for some of the less noisy alternatives, the base population will be considerably larger than the population actually affected by those alternatives. If the base $L_{dn}(y)$ is consistent with the screening diagram,

no person exposed to project noise levels less than the base $L_{dn}(y)$ would be regarded as impacted.

There are cases when, over time, people will move into or out of a project area at the same time the project is expanding and environmental noise levels are increasing. Such changes in population may be entirely unrelated to the project under analysis. In these cases it may be necessary to define several base populations or base areas, one for each year of interest. (See Appendix E, section E.2 for an example of this type of analysis.)

There are actions that do not add new noise sources, but only change the noise output of existing sources. In these cases, the changed source should be treated as a new source for purposes of determining the base population.

There are actions that will move people into noisy areas. For these cases, the base population will be the total population who will be living in an area where the existing yearly L_{dn} is greater than 55 dB.

There are actions which affect large segments of the population that are not easily related to specific areas. Laws and regulations that directly affect mobile noise sources are examples of such actions. For actions affecting regulation of noise sources in general, the base population might best be described as the total population experiencing day-night sound levels above 55 decibels from such sources. For actions affecting source control for equipment operators, the base population might be only the users of the specific noise source. In the final analysis, the preparer of a noise impact analysis must use his or her judgment. In all cases, an explanation should be included in the final report of how the base population was determined.

Population estimates for residential areas identified in the analysis may be taken directly from census tract data, local master plans, or by counting residential units identified on aerial photographs of the area.

DEPT CONN ARCH ARCH

Non-residential populations may be estimated from industrial, commercial, or public facility employee statistics; student enrollments and employee statistics can be used to estimate school populations. Population estimates should strive to identify total populations within an accuracy of ± 10 percent. It is recognized that in many situations such a degree of accuracy is unattainable. In such cases the users of these guidelines should put forth the best generalized estimates possible, documenting the basis or procedures employed in making these estimates. One way to deal with uncertainty in predicting future populations is to use the local community's land use plans or zoning designations, whenever they exist, to estimate the most likely future population density.

2.2 Health and welfare effects

This section deals with the most commonly experienced noise problems, the general health and welfare effects of noise due to the noise environment encountered in most urban and suburban areas. Those effects are the major concern at yearly L_{dn} values which range approximately from 55 dB to 75 dB. Summaries of these effects are described in Appendix C. Above 75 dB, the possibility of severe health effects need to be considered (see section 2.3.) in addition to the effects discussed here. The first subsection describes the health and welfare criteria which apply in this range of general audible noise, and the second covers the procedures to be used to quantify those effects.

2.2.1 Human noise exposure criteria

As the primary criterion for evaluating the impact of noise on people, the effect on "public health and welfare" was selected in the Levels Document [2]. Interference with speech communication, with general well-being, and with sleep are related to the general annoyance produced by the noise

environment, and were accepted as indicators of effects on public health and welfare. The same criteria are proposed here as the basis for environmental impact assessment.

A summary of the expected effects of noise on human activities for outdoor yearly day-night sound levels of 55, 60, 65, 70, and 75 dB, in terms of health effects, interference with speech communication, community reaction, annoyance, and attitude towards the area is provided in Appendix C. Basic information in these tables on speech intelligibility and general community reaction was derived from the Levels Document [2]. The relationships given in the Levels Document between noise and annoyance have been modified in the light of a substantially increased set of data subsequently available [6]. These tables allow the preparer of a noise analysis to make an explicit statement as to the expected impact of any day-night sound level.

In order to achieve the simplicity which these guidelines are intended to promote, it is desirable to be able to summarize these several health and welfare effects with a single indicator. The response of interest is the general adverse reaction of people to noise, which includes speech interference, sleep interference, desire for a tranquil environment, and the ability to use the telephone, radio, and television satisfactorily. A measure of this response is the percentage of people in a population that feels high annoyance about noise of a specified level. High annoyance is selected on both theoretical and practical grounds. First, it arises as a consequence of the activity interference and interruption caused by noise [17], and therefore summarizes all the effects better than any one of the direct effects would. Second, there is available a large set of data which allows response, expressed as percentage of a population highly annoyed, to be characterized by a single functional relationship of the noise environment [6].

The percentage highly annoyed is used rather than the percentage at all annoyed for a number of reasons [6, pp. 378-379]. Perhaps the most important of these is that when people are highly annoyed by noise the effects of non-acoustical variables are reduced, and the correlation between noise exposure and the expressed subjective reaction is high. This is not to say that all individuals have the same susceptibility to noise; they do not. Even groups of people may vary in their response to noise, depending on previous exposure, age, socio-economic status, political cohesiveness and other social variables. In the aggregate, however, for residential locations, the average response of groups of people, as measured by the percentage highly annoyed, is quite stably related to cumulative exposure to noise as expressed in a measure such as L_{dn} .

For schools, offices, and similar spaces where ease of speech communication is of primary concern, the same relationship can be used to estimate the potential average response of people, taken as a group, ignoring individual variations from person to person.

Data used to relate annoyance to noise environment in the Levels Document [2] was based on two social surveys around airports in the United States and England. Data have now been analyzed from 19 social surveys (in 9 countries) associated with aircraft, urban traffic, freeway traffic, and railroad noise [6]. These data allow a much more definitive relationship to be developed between percentage of the population highly annoyed and average noise level. The data support the previous assumption that the statistical relationship between population annoyance and noise level is essentially independent of the type of noise source [18].

The results of this synthesis show quite clearly that the best fit of response data to average sound level is provided by a curvilinear function; originally a cubic equation was used in the regression analyses. Further, 12

of the surveys, covering aircraft, railroads, urban traffic, and expressway traffic as noise sources, "clustered" closely around an average curve for the set of data, as shown in Figure 4. The remaining 7 surveys showed similarly shaped annoyance/sound level functions, but deviated in differing detail from the 12 clustering surveys for various qualitative reasons [6]. It is worth noting that the average of the non-clustering surveys was essentially the same as the average for the clustering surveys.

Based on these data, Schultz proposes the following equation "as the best currently available estimate of public annoyance due to transportation noise of all kinds" [6, p. 382], relating percent highly annoyed, (%HA), to day-night sound level:

$$\%HA = 0.8553 L_{dn} - 0.0401 L_{dn}^2 + 0.00047 L_{dn}^3 \quad \text{Eqn. 2a}$$

This expression represents the least-squares fit of percent highly annoyed to day-night sound level for the clustering survey data.

A second form of this equation, based on two power law functions, is preferred on the grounds that it suggests an explanation for the behavior represented in equation 2a. At lower levels, the first power function represents increasing awareness, or arousal. At higher levels, annoyance increases at the same rate as the well-known loudness function, represented by the second power function. The smoothed version of the function based on the two power law functions is expressed as*:

*Another very useful and simpler expression which approximates the annoyance function is:

$$\%HA = \frac{100}{1 + e^{(10.43 - 0.132 L_{dn})}}$$

This expression has the particular advantage of not allowing predicted values to go below zero percent or above 100 percent.

DEPT. OF ENVIRONMENTAL AFFAIRS

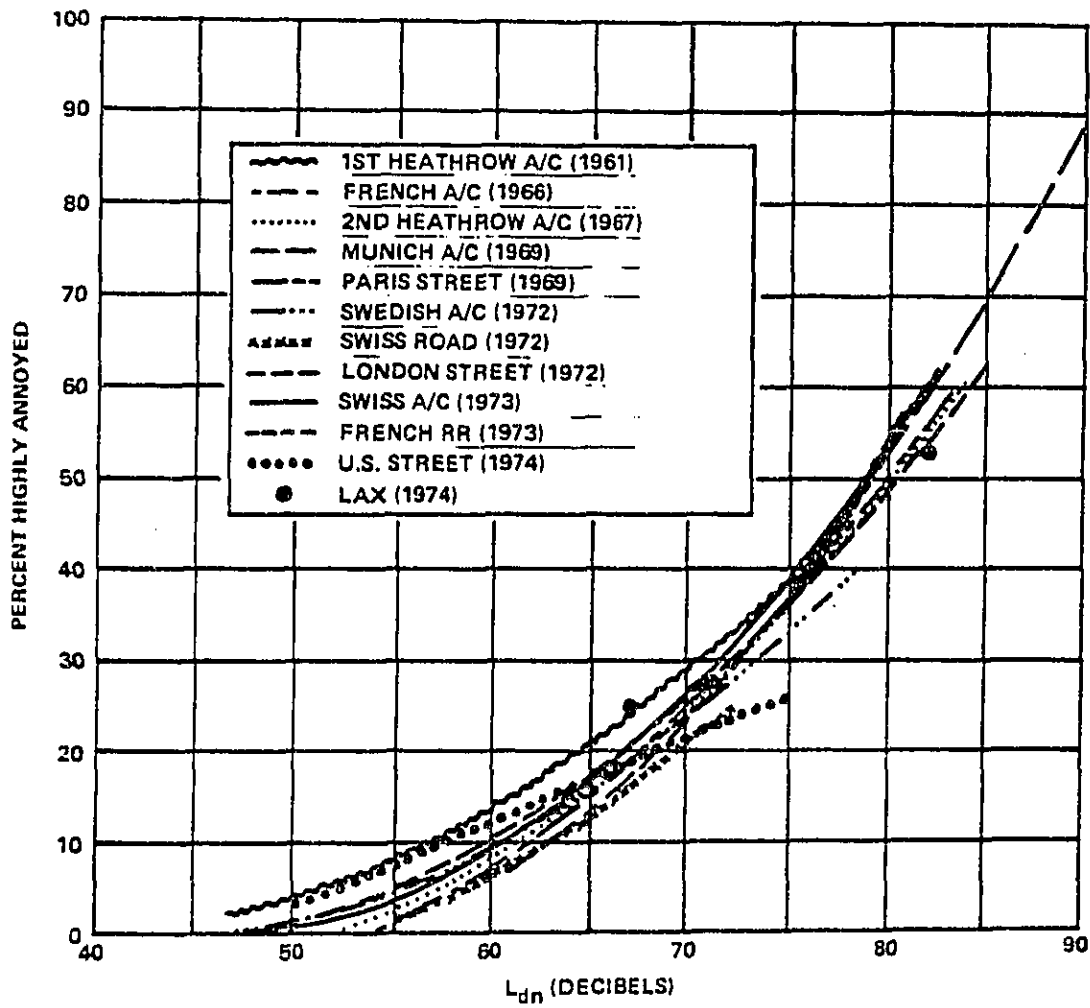

FIGURE 4. SUMMARY OF ANNOYANCE DATA FROM 12 SURVEYS SHOWING CLOSE AGREEMENT
SOURCE: SCHULTZ [6]

$$\%HA = \frac{(1.24 \times 10^{-4}) (10^{0.103 L_{dn}})}{(1.43 \times 10^{-4}) (10^{0.08 L_{dn}}) + (0.2) (10^{0.03 L_{dn}})} \quad \text{Eqn. 2b}$$

In the absence of any studies relating average response to noise level for non-transportation sources, equation 2b has been adopted in these guidelines for use as the criterion for all noise sources. If information becomes available which identifies a different relationship for certain sources, the guidelines may be revised accordingly.

This function for the percentage highly annoyed differs from previously suggested equations, including the one in the Levels Document [2, p. D-27], as is illustrated in Figure 5. The relationship shown in the Levels Document was taken from a study by an EPA Task Group under the EPA Aircraft/Airport Noise Study in 1973 [19]. In this study, social survey data from the first study around Heathrow airport in England [20], and from the Tracor study of U.S. airports [21] were combined to develop a relationship between "percent highly annoyed" and day-night sound level. This function was expressed as:

$$\% \text{ Highly Annoyed} = 1.8 (L_{dn} - 46) \quad \text{Eqn. 3}$$

The Task Group also noted a similar relationship developed in an OECD study [22] that used the relationship:

$$\% \text{ Highly Annoyed} = 2 (L_{dn} - 50) \quad \text{Eqn. 4}$$

This equation was also based on airport noise studies. The primary reason for these differences is a redefinition of what is meant by highly annoyed. In fact, the Heathrow study is included in the clustering surveys (Figure 4). As Schultz's paper makes clear [6, pp. 391-392], the annoyance scale used in the first Heathrow study requires some interpretation: it is not a direct question about degree of annoyance. The earlier analysis (Eqn. 3) considered the top three scale points as highly annoyed; Schultz used only

DIRECTOR, ENVIRONMENTAL QUALITY

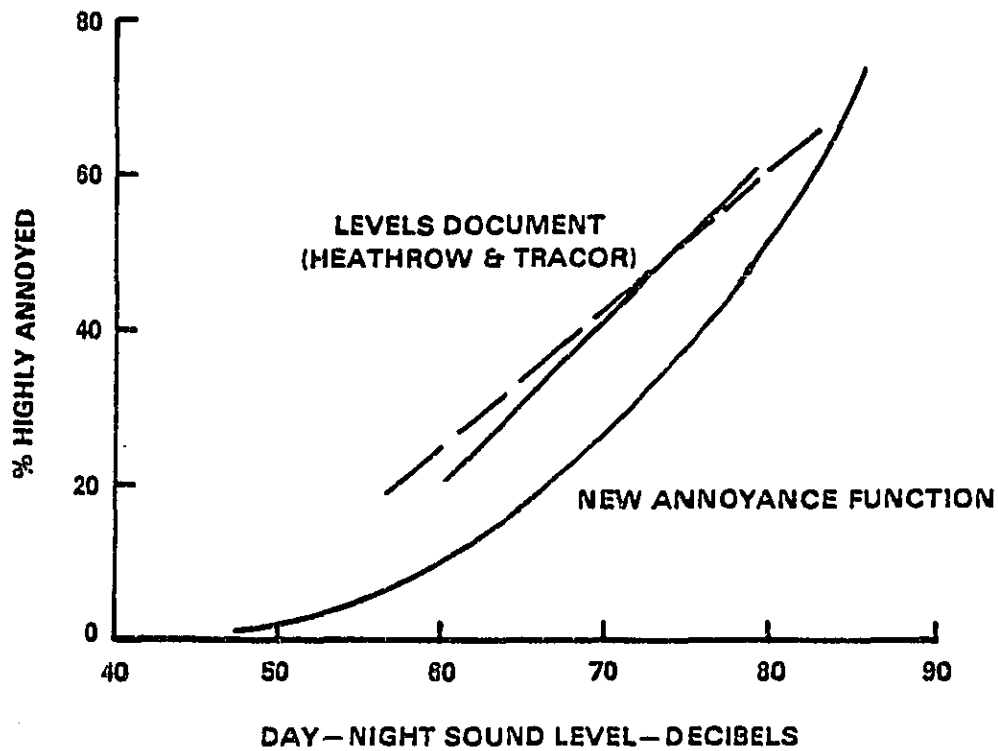

FIGURE 5. COMPARISON OF NEW ANNOYANCE FUNCTION WITH PREVIOUS FUNCTIONS

the top two. His discussion is persuasive, and his function has been adopted for these guidelines.

It is important to point out that this redefinition of annoyance does not affect the conclusions reached in the Levels document, because that document relied on speech and sleep interference indicators to identify the actual levels which were "requisite to protect the public health and welfare with an adequate margin of safety." That approach led to the statements that a day-night sound level of 55 decibels in residential areas will result in negligible impact on public health and welfare and that the degree of impact will increase as the day-night sound level increases. The EPA Levels Document [2] asserts that no significant effects on public health and welfare occur, for the most sensitive portion of the population and with an adequate margin of safety, if the prevailing day-night sound level is less than 55 decibels. The difficulty with using annoyance for such a calculation is obvious in Figure 5: there are still some people affected at sound levels as low as 45 dB (L_{dn}). These guidelines, then, use as the criterion in populated areas the function given by Eqn. 2, which shows some impact at levels as low as 45 dB, impact which is fairly low into levels in the low 60's (dB), and impact which begins to increase fairly rapidly above 65 or 70 dB (L_{dn}).

For those events in which the single event measure, sound exposure level, is used to describe the noise environment, the previous discussion will not apply. Information characterizing response as a function of sound exposure level is not readily available. Some information can be approximated for sleep interference [23,24,25,26] and speech interference [24,26], but it is not as easily dealt with as is the information on L_{dn} .

2.2.2 Quantification of the noise impact

The impact of a noise environment on people regularly experiencing the environment is the degree to which the noise interferes with various activities such as speech, sleep, listening to radio and television (i.e., the peaceful pursuit of normal activities), and the degree to which it may impair health, through, for example, the inducement of hearing loss. Sound levels produced by sources being considered in an environmental assessment will generally vary with distance from the source, sometimes over a large geographic area. As a consequence, people occupying different geographic areas will experience different sound levels. The total impact of a particular noise environment is a function of both sound level and the size of the population experiencing a particular value of sound level.

The first step in describing the noise impact of an action is to tabulate the number of people regularly experiencing various sound levels. In many cases, particularly those in which noise impacts must be compared with a variety of other costs and benefits, such a tabulation is insufficient, because it contains too much information. In those cases, it is desirable to derive a single number which represents quantitatively the integrated impact of the action on the total population experiencing the different sound levels. This single number quantification is defined below as the sound level-weighted population, LWP. Sound level-weighted population, together with the tabulations of populations experiencing sound levels of a specified value, constitute the minimum quantification of environmental impact of noise recommended in these guidelines. This subsection describes procedures for preparing the tabulations, and for calculating the sound level-weighted population. It also describes a useful second descriptor of noise impact, the noise impact index, NII, which is formed by the ratio of sound level-weighted population to the

total base population. The procedures proposed here do not rely on establishing specific criterion noise levels for different land use categories. (For information on criterion levels suggested by different organizations, see Appendix B.)

a. Necessary tables - As a minimum the data characterizing the noise impact should be tabulated in a set of summary tables. Typical tables are included in the example in section 2.6 (Tables 6 through 9). For a given year the areas and population are to be listed against the yearly day-night sound level at increments not greater than five decibels, for the following estimated noise environments:

- (1) without the project's existence;
- (2) due solely to the project action;
- (3) due to all sources including the project action.

All three tables may not always be necessary, especially if there are insignificant differences between any two of the tables.

If the tables are properly constructed, the total population and/or land area for each of the three conditions will be equal (i.e., will equal the base population or area defined in section 2.1.3). The tables should include enough increments of yearly L_{dn} that all residential populations, industrial, commercial land and special situations experiencing L_{dn} values above the base L_{dn} are included.

The column headings might typically include: total land area, industrial/commercial land area, residential land area, industrial/commercial employees, residential population, and special situations. Depending upon local conditions, different classifications of land use may be appropriate. Industrial/commercial land area is meant to include all land not considered as residential or associated with special functions. This land area would include farm

land, undeveloped land, industrial plants, and similar uses. Depending on local plans, this category may be further broken down. Residential land includes all land associated with a residential population. It may include land actually zoned commercial or industrial. For residences on farm lands, approximately 1 acre should be considered as residential land for each separate residence.

Special situations are those situations which must be highlighted or treated separately in order to represent the impact properly. Situations of this category can be religious facilities, outdoor auditoriums, schools, precision laboratories, hospitals, etc. The detail to which each special situation should be discussed will depend on the size of the project and the size of the area being evaluated. Special situations should be combined as necessary to keep the total number of special situations within reason (normally less than 20 or 30 items). One useful approach to the listing of special situations is to number each one, and then to use this number in the special situation column to indicate the corresponding L_{DN} for that situation (see examples, section 2.6, Tables 6 through 8).

If there are more than a few special situations, an additional table summarizing them will also be useful (Table 9 in the example in section 2.6). This should list the number of exposed people for each situation. At some locations the population does not remain constant from day to day, week to week, or month to month. Examples of such places are churches, parks, and stadiums. In such situations the population entered in the special situation table is the time-weighted average number of people present during the year. This number should be calculated by summing the products of the number of people using a facility, multiplied by the number of hours these people are present in the facility during a year, and dividing by the total number of

hours in a year. If a noise measure other than yearly L_{dn} is being used, the average number of people can be calculated similarly for that time period, such as the working day for office buildings. The concept of average number should not be used for residential areas.

Formats other than that used in Tables 6 to 9 may be appropriate and may be used; however, the information conveyed to the reader should be effectively the same as or greater than is contained in these tables.

For each alternative of a permanent project or action, a separate set of tables as outlined above should be prepared for (1) the first year of the commencement of the project, (2) the last year before the end of the project (or at the 20-year point, whichever is shorter), and (3) the worst case year if such a year is not the first or last year. In many cases, only one of these sets will be necessary because the conditions with respect to time can be expected to remain reasonably constant. By "reasonably constant," it is meant that the change in exposed population will be small enough so any resulting errors are consistent with the error in the overall analysis.

In addition to the tables, it would be helpful to present a map or drawing of the area including surrounding facilities such as airports, factories, highways, or electrical plants, with contours representing constant values of yearly day-night sound level. In general, the decibel increments between contours should be consistent with the tables as discussed above. Other contours may be presented as needed. There should be a set of contours for each of the alternatives studied.

b. Sound level-weighted population - For those projects in which it is necessary to compare or trade off noise impacts with other costs and benefits of a proposed project, a compilation of the data characterizing noise impacts into the tables described above will usually not prove sufficient.

The tables contain too much information for easy comparison to be possible. A single number representation, combining the extensity (number of people exposed) and intensity (severity of the exposure) of the noise impact is desirable. Using the criterion function based on the percentage highly annoyed (Eqn. 2), described in section 2.2.1., such a single-number index can be constructed which summarizes the impact in terms of the total number of people who respond adversely to the effects of noise.

Several assumptions are made in this method of analysis.

(1) The intensity of human response is a measurable consequence of equivalent sound level, and in the noise range of interest here (namely that generally encountered in populated areas), is appropriately measured as the percentage of the population which is highly annoyed.

(2) When measured this way, it is clear that the impact of high noise levels on a small number of people is equivalent to the impact of lower noise levels on a larger number of people in an overall evaluation, when both yield the same number of people responding adversely. Thus the properties of intensity (level of sound) and extensity (number of people affected by the sound) can be combined mathematically.

(3) On the basis of these two assumptions one can ascribe differing numerical degrees of impact to different segments of the population of concern, depending on the equivalent sound level, and can sum over all of these segments to obtain the total impact (total number responding adversely).

On the basis of these assumptions, the following equation is obtained for the sound level-weighted population, LWP:

$$LWP = \int P(L_{dn}) \cdot W(L_{dn}) d(L_{dn}) \quad \text{Eqn. 5}$$

where $P(L_{dn})$ is the population distribution function, $W(L_{dn})$ is the weighting function described in Equation 2b, characterizing the severity of the impact

as a function of day-night sound level (Table 3), and $d(L_{dn})$ is the differential change in day-night sound level. Although Table 3 contains values for L_{dn} as low as 35 dB, the values below 45 dB should be used only with great caution, as they represent extrapolation beyond the range of the data [6]. In any event, for most projects in populated areas, the future noise level even without the project will probably be considerably higher than the 45 dB limit of the data.

It is usually not necessary or possible to use the integral form to compute LWP. Sufficient accuracy is obtained by taking average values of the weighting function between equal decibel increments, up to 5 decibels in size, and replacing the integrals by summations of successive increments in average sound level:

$$LWP = \sum P(L_{dn})_i \cdot W(L_{dn})_i \quad \text{Eqn. 6}$$

where i indexes the successive increments in average sound level.

c. Noise impact index - The sound level-weighted population is a measure of the total noise impact of a proposed alternative. In many cases it will be the only summary indicator needed for comparing alternatives. In other cases, where the base population is not constant (for example when comparing projects in different locations), the noise impact index (NII) will be a useful concept for comparing the relative impact of one noise environment with that of another. It is defined as the sound level-weighted population divided by the total population under consideration:

$$NII = \frac{LWP}{P_{Total}} = \frac{\sum P(L_{dn})_i \cdot W(L_{dn})_i}{\sum P(L_{dn})_i} \quad \text{Eqn. 7}$$

where the functions are the same as described above, and P_{Total} is equal to the base population (defined in section 2.1.3).

TABLE 3

VALUES OF THE WEIGHTING FUNCTION FOR GENERAL ADVERSE RESPONSE*
 $[W(L_{dn}) = (0.01)^{ZHA}]$

<u>L_{dn}</u>	<u>W(L_{dn})</u>	<u>L_{dn}</u>	<u>W(L_{dn})</u>	<u>L_{dn}</u>	<u>W(L_{dn})</u>
35	0.002	52	0.030	69	0.224
35.5	0.002	52.5	0.032	69.5	0.234
36	0.003	53	0.035	70	0.245
36.5	0.003	53.5	0.037	70.5	0.256
37	0.003	54	0.040	71	0.267
37.5	0.003	54.5	0.043	71.5	0.279
38	0.003	55	0.046	72	0.291
38.5	0.003	55.5	0.049	72.5	0.303
39	0.004	56	0.052	73	0.315
39.5	0.004	56.5	0.056	73.5	0.328
40	0.005	57	0.060	74	0.341
40.5	0.005	57.5	0.064	74.5	0.355
41	0.006	58	0.068	75	0.369
41.5	0.006	58.5	0.072	75.5	0.383
42	0.007	59	0.077	76	0.397
42.5	0.007	59.5	0.082	76.5	0.412
43	0.008	60	0.087	77	0.427
43.5	0.008	60.5	0.092	77.5	0.443
44	0.009	61	0.098	78	0.459
44.5	0.010	61.5	0.104	78.5	0.475
45	0.011	62	0.110	79	0.492
45.5	0.011	62.5	0.116	79.5	0.509
46	0.012	63	0.123	80	0.526
46.5	0.013	63.5	0.130	80.5	0.544
47	0.014	64	0.137	81	0.562
47.5	0.015	64.5	0.144	81.5	0.581
48	0.017	65	0.152	82	0.600
48.5	0.020	65.5	0.160	82.5	0.620
49	0.019	66	0.168	83	0.640
49.5	0.021	66.5	0.176	83.5	0.660
50	0.023	67	0.185	84	0.681
50.5	0.024	67.5	0.194	84.5	0.703
51	0.026	68	0.204	85	0.725
51.5	0.028	68.5	0.214		

*When using decibel bands of increments greater than 1 dB, use the Weighting Function that corresponds to the mid-point of the band. For example, to determine $W(L_{dn})$ for the 60-65 dB band, use 62.5 dB (the mid-point of the band) to estimate the Weighting Function, which in this example, would be approximately 0.116.

d. Change in level-weighted population and relative change in impact -

A primary concern in an environmental noise assessment is a comparison of (1) the effect of the action on the noise environment with (2) the environment before the action was to take place. Two additional descriptors of this change due to the action are useful. The first descriptor is simply the numerical change in sound level-weighted populations before and after the action, the change being an increase or decrease in sound level-weighted population (or the neutral effect case, no change). The second descriptor is the relative change in impact (RCI), where the effect of the action is expressed as the value of the change in the sound level-weighted population after the action, divided by the sound level-weighted population before the change:

$$RCI = \frac{LWP_a - LWP_b}{LWP_b} \quad \text{Eqn. 8}$$

where LWP_a is the impact after the action or project is in place, and LWP_b is the impact before the action is taken.

e. Level-weighted area - In those rare cases where it is known that an area will be developed, but there is no information with which to predict the future population, it may be necessary to calculate a level-weighted area, as a proxy for the population impacts. Such a calculation would be equivalent to that for level-weighted population (equation 6), but would use the tabulation of area within decibel intervals, rather than population, assuming, in effect, a constant and undefined population density.

f. General discussion - A number of different noise impact descriptors are available, based on the four single-number indexes (level-weighted population, noise impact index, change in level-weighted population, and relative change in impact) and the three noise characterizations (the project alone,

the environment without the project, and the total future noise environment obtained by combining the other two). The result is almost a confusion of supposedly simplifying descriptors. Two or three of these will be most useful in each case, depending on the relationship between project levels and expected levels without it (Figure 6). Where existing levels are already high, the level-weighted population or noise impact index based on the project noise alone is suggested as the best descriptor. The other descriptors will minimize the impact by putting it on relative terms. Where project levels are much higher than existing levels, the project levels will dominate the combined levels, so either will give the same result. Where project levels are similar to existing levels, it is necessary to use the combined levels to identify the full impact.

For projects which will move people into areas with L_{dn} values above 55 dB, and for projects which reduce noise, Figure 6 is not applicable. Projects, such as housing developments in areas with L_{dn} above 55 dB, need to be evaluated in terms of the level-weighted population or noise impact index based on the non-residential noises to which they will be exposed (e.g. road traffic or aircraft noise). The only basis for calculating the change in level-weighted population or relative change in impact which might be useful in such a situation is one based on the national average NII, which has been calculated to be 0.35. Projects which reduce noise, on the other hand, should be evaluated on the basis of the change in level-weighted population, or relative change in impact. Since the project is proposed to reduce noise, it is obviously the reduction or change which is of interest.

Relationships between annoyance and average sound level have been used previously to define a weighting function for the numerical evaluation of impacts. It is useful to compare the present function (Eqn. 2 and Table 3)

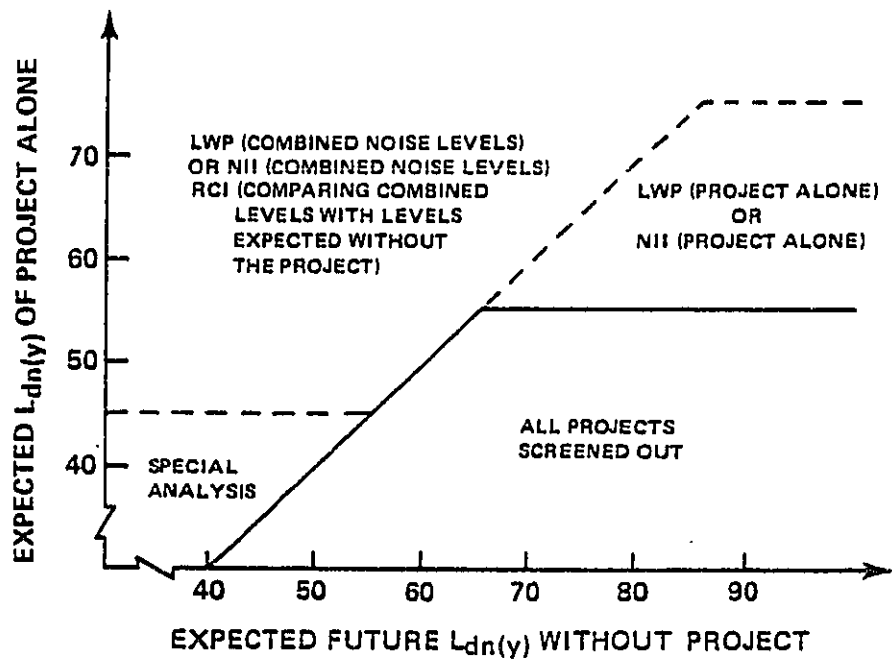

FIGURE 6. SUGGESTED DESCRIPTORS FOR VARIOUS SITUATIONS

to the one used earlier by EPA, which was first introduced in the fractional impact method developed initially for use in the analysis of highway noise problems [27]. This method took into account the data and recommendations both of the EPA Levels document [2], and of the earlier report on Impact Characterization of Noise [19], which indicate that a community would not be expected to exhibit significant reaction at noise exposures of $L_{dn} = 55$ dB or below, but would be expected to show strong, organized reaction at $L_{dn} = 75$ dB and higher. Using these two anchor points and the linear relationship of Equations 3 and 4, a weighting function called fractional impact (F.I.) was defined to be zero at $L_{dn} = 55$ dB, and unity at $L_{dn} = 75$ dB, varying linearly with average sound level, such that:

$$F.I. = 0.05 (L_{dn} - 55) \qquad \text{Eqn. 9}$$

The weighting function for F.I. has been used by EPA in impact analyses of a number of potential regulatory actions.

Several features of equation 9 are unsatisfactory. It is not likely that community response is adequately described with a linear function of average noise level over a wide range of levels. Even though the data from the individual social surveys are reasonably well fitted by linear regressions over the limited range of levels represented in the separate surveys, the individual survey results indicate that the rate of change of annoyance with sound level is greater at higher sound levels than at lower sound levels. Moreover, the choice of an arbitrary zero at $L_{dn} = 55$ dB is not easily justified. Finally, few data from noise sources other than aircraft were available at the time the original weighting functions were developed, and a weighting function derived only from aircraft-related social surveys may not be satisfactory for use in evaluating other sources of noise.

Despite these flaws, however, this linear function is quite similar in its relative ratings to the curvilinear function used in this document (Eqn. 2). If the two functions are placed on the same scale (Figure 7), it can be seen that, in the day-night sound level range of 55 to 80 decibels, this linear weighting function will generate relative values for level-weighted population that differ only by the order of one percent from the curvilinear weighting function in many applications. The change in scales necessary to make this comparison stems from the fact that fractional impact was defined to be unity at $L_{dn} = 75$ dB, while the present function is based on the number of people reporting a high degree of annoyance in a social survey situation. Both are equally legitimate interpretations of available impact: the first provides an indicator of absolute impact, while the second is more easily understandable in comparisons with other costs and benefits of proposed projects. Because the linear function (Eqn. 9) closely approximates the curvilinear relationship (Eqn. 2) between the day-night sound level range of 55 to 80 dB, the user may wish to employ the more simple linear relationship in some cases.

2.3 Severe health effects

In some high level noise environments people will be exposed regularly to 24-hour equivalent sound levels in excess of 70 decibels. In these environments special consideration should be given to the potential for severe health effects. This section discusses the criteria to be used for describing severe health effects, and then describes a procedure for calculating a single number index, analogous to the level-weighted population index, for statistically summarizing expected severe health effects.

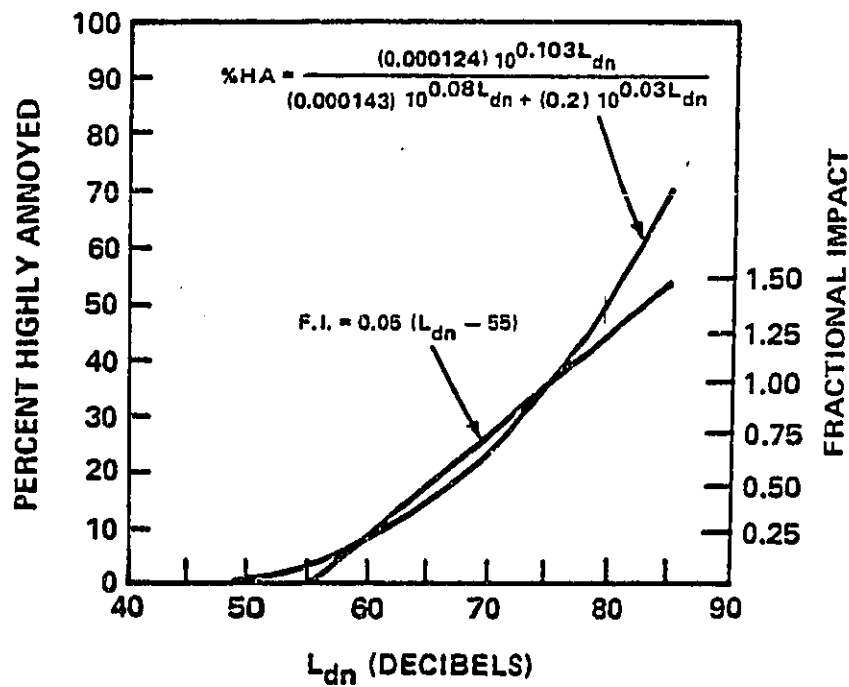

FIGURE 7. COMPARISON OF CURVILINEAR FUNCTION AND FRACTIONAL IMPACT LINEAR FUNCTION

2.3.1 Human noise exposure criteria

The discussion of severe health effects in an environmental analysis is meant to supplement the discussion of general adverse effects, not to replace it at high noise levels. The general adverse effects - speech interference, sleep interruption, annoyance - continue to be present at high noise levels, and in fact increase more rapidly at the higher noise levels. Equation 2 (or Table 3) can be used to summarize these effects for L_{dn} values as high as 85 dB. These effects, however, only include those of which people are aware, and which have been articulated in attitudinal surveys. In many instances, people are not aware of the potential severe health effects which long-term noise exposure can cause. Hence a separate discussion of severe health effects is necessary, which helps to emphasize the severity of the problems caused by high noise levels.

Noise-induced hearing loss can begin to occur at high noise levels. Other noise-induced physiological effects and/or changes may occur. However, a firm causal link between community noise and extra-auditory disease has not been established at this time. Therefore, this document proceeds on the assumption that protection against noise-induced hearing loss is sufficient to protect against severe extra-auditory health effects.* However, one has to keep in mind that as the noise level increases above the threshold for severe health effects, so does the probability that other health effects in addition to noise-induced hearing loss might become important. The adverse effect of noise on hearing rapidly accelerates as the noise exposure increases and it

*This is not to say that non-auditory physiological effects do not occur at levels below those sufficient to protect against hearing damage. In any event, rigorous causal links between noise and extra-auditory health effects have not yet been firmly established, but await further study.

is reasonable to use expected noise-induced hearing loss as a basis for assessment of severe health effects.

A problem arises in specifying the noise measure to be used when quantifying severe health effects. If hearing loss is used as the indicator, the noise measure needs to reflect at-ear measurement to be valid. Further, hearing loss is properly expressed as a function of L_{eq} , rather than of L_{dn} , but it will not usually seem warranted to calculate and draw noise contours for more than one noise measure. The data to be discussed below predict noise-induced permanent threshold shift (NIPTS) for 8-hour equivalent sound levels (at-ear) starting at values of 75 dB. If the remaining 16 hours of the day are spent in a noise environment of 70 dB L_{eq} or lower, the at-ear 8-hour equivalent sound level of 75 dB results in a 24-hour long L_{eq} of approximately 70 dB, at the ear. For many proposed projects (particularly actions where assessment of hearing damage risk is of primary concern) it will be appropriate to use one of these two measures.

It is also important to be able to identify the L_{dn} values at which it is appropriate to look for severe health effects. Those persons who have the greatest outdoor activity, including young children, retired persons living in warm climates, and people in certain outdoor occupations, are clearly the people of major concern when outdoor L_{dn} is considered. For outdoor exposure, daytime levels are the important ones for establishing at-ear values. The values of L_{dn} corresponding to an A-weighted equivalent sound level of 75 dB during daytime hours range between 73 and 81 dB. The lower value corresponds to a situation where the equivalent sound level during the night is 20 dB or more lower than that occurring during the day, whereas the higher value corresponds to the situation when the equivalent sound level during the night equals that occurring during the day. The most probable difference

between the daytime and nighttime values of L_{eq} is 4 dB, as shown for the noise levels of interest in Fig. A-7 of the Levels document [2]. For this day-night difference, L_{dn} is three decibels above the daytime value of L_{eq} , that is, $L_{dn} = 78$ dB. This value of 78 dB is considered to be the most probable value of L_{dn} to be found in real environments that have a daytime L_{eq} of 75 dB. (This estimation is based on that in reference 19, pp. B-8 - B-9.) However, due to the wide range of possible values, it is recommended that an outdoor L_{dn} of 75 dB be used as the threshold above which severe health effects are investigated. This has the advantage of being an L_{dn} value for which contours will already be mapped, and is therefore information readily available.

Consequently, for areas with L_{dn} of 75 dB or above, it is important to look for potential severe health effects. The way to do this is to estimate the size of the population spending time outdoors, the length of time they are outdoors, and the actual levels while they are outdoors. The last two of these numbers can then be used to estimate the at-ear 24-hour L_{eq} for these people (using the equation for L_{eq} in Appendix A). As long as the outdoor noise exposure exceeds 3 hours per day, the contribution of the indoor noise environment may be neglected in computing the 24-hour L_{eq} . This conclusion does not depend greatly on the actual noise attenuation provided by the house so long as the attenuation is greater than 10 dB [19, p. 8-9].

There have been numerous studies conducted for the purpose of determining the long term effect of noise on the hearing ability of an exposed population. In particular, three studies [28,29,30] have provided reasonable predictive models of the relationship between noise exposure and changes in the statistical distribution of hearing levels of the exposed population. These changes are called Noise Induced Permanent Threshold Shifts (NIPTS). The results of

these three studies were combined [31] and used in the EPA Levels document [2, Table C-1], to provide a summary of the expected NIPTS that would occur from a 40 year exposure beginning at an age of 20 years.

Inspection of Table C-1 in the EPA Levels Document [2] shows that as the average sound level of the exposure increases, there is a widening of the frequencies affected by the exposure. As would be expected, the average of 500 Hz, 1000 Hz, 2000 Hz and 4000 Hz does not show a uniform constant increase in loss with a rising exposure level, but instead increases at an accelerated pace with increasing average sound level. While use of the most sensitive frequency is proper for the determination of an absolutely safe daily equivalent sound level, assessment of the relative impact of exposure to higher equivalent sound levels requires that all audiometric frequencies be considered. Therefore the average of 0.5 kHz, 1 kHz, 2 kHz, and 4 kHz is the recommended measure. Since each of the four frequencies describes the center of the preferred octave bands, there is no overlapping in octave bands as would be the case if 3000 Hz was included.

Having selected a method to handle the question of frequency, the next problem is time. One way to consider time is to select a point in time at which the relative impact will be described. Selection of such a point is somewhat arbitrary and not entirely meaningful. For instance one could argue that it is more important to describe the effects of noise when a person is middle-age, and not when a person is 60 years old. An alternative approach is to use the average NIPTS of the population during or over a normal working lifetime. Averaging NIPTS with respect to time avoids arbitrarily selecting any one point in time and provides a realistic assessment of the overall effect of noise on hearing on a large population, recognizing that many individuals, because of differences in sensitivities and ages or lengths of

exposure, may incur either more or less hearing loss than would be assessed using this procedure.

A grand averaging of the NIPTS with respect to frequency (0.5 kHz, 1 kHz, 2 kHz, 4 kHz) and time (0 to 40 years of exposure) and percentiles (0.1 to 0.9 percentiles) from references 2 and 31 is listed in Table 4. These NIPTS data can be very well described by the formula:

$$\text{Ave NIPTS} = (L_{\text{eq}}(8) - 75)^2/40 = (L_{\text{eq}}(24) - 70)^2/40, \quad \text{Eqn. 10}$$

where "Ave NIPTS" is the average NIPTS as discussed above. The slight differences shown in Table 4 between equation 10 and the NIPTS data should be considered insignificant, especially in view of the fact that the original data were rounded to the nearest whole integer in any case.

TABLE 4
AVERAGE HEARING LOSS AS A FUNCTION OF 8-HOUR L_{eq}

$L_{\text{eq}}(8)$ dB	Ave. Hearing Loss dB*	$(L_{\text{eq}}(8) - 75)^2/40$ dB
75	0	0.0
80	1	0.625
85	3	2.5
90	6	5.625
95	10	10.0

Equation 10, then, is the criterion for estimating the potential severe health effects due to a proposed project. For applications, it can be calculated directly, read from Table 5, or read from Figure 8. The outdoor day-night sound level, L_{dn} , should be used only to identify potential problem areas. Within those areas, an effort should be made to estimate the actual

*Source: Table C-1 of Levels Document [2], and Johnson [31]

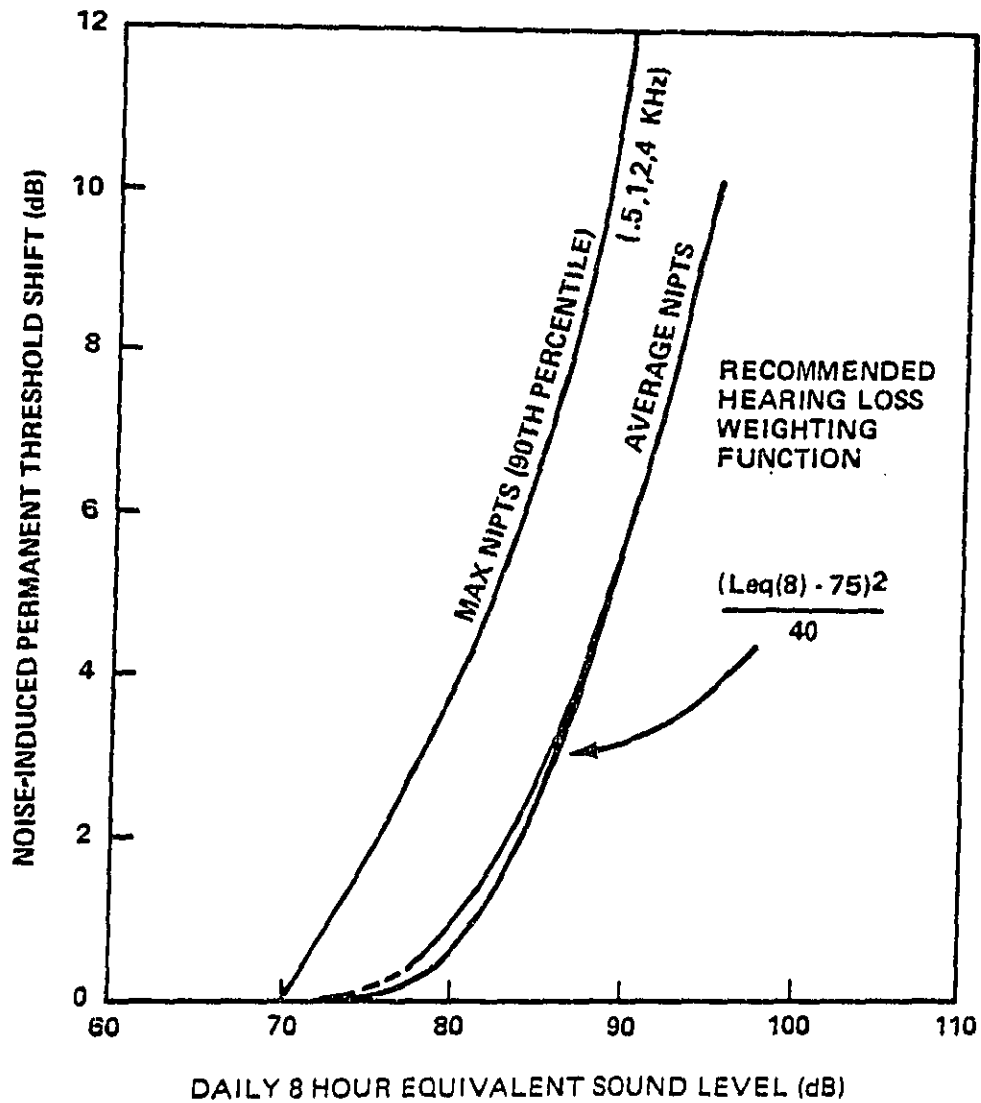

FIGURE 8. POTENTIAL HEARING DAMAGE RISK FOR DAILY EXPOSURE TO 8 HOUR EQUIVALENT SOUND LEVELS

Table 5

CRITERION FUNCTION FOR SEVERE HEALTH EFFECTS

<u>L_{eq}(8) or L_{dn}</u> <u>(dB)</u>	<u>L_{eq}(24)</u> <u>(dB)</u>	<u>dB loss</u>
75	70	0
76	71	0.025
77	72	0.100
78	73	0.225
79	74	0.400
80	75	0.625
81	76	0.900
82	77	1.225
83	78	1.600
84	79	2.025
85	80	2.500
90	85	5.625
95	90	10.0

exposure of groups of people. In any application, it should be remembered that since this equation was developed from averaging the effects of noise over frequency, time, and percentiles, it cannot estimate the effect on an individual at one audiometric frequency at one point of time. This equation should be used only to assess the average relative impact of exposure to different equivalent sound levels.

It is also useful to look at individual susceptibility to noise induced hearing loss. Therefore, a user may wish to consider the NIPTS for the most sensitive ten percent of the population after 40 years of exposure. This information can be read from the 'Max. NIPTS 90th Percentile' curve of Figure 8.

2.3.2 Quantification of the impact

The first step in quantifying the impact is to construct the tables indicating the number of people within decibel intervals. In many instances the same tables setting out the extent of the general audible noise impact can

serve for this noise range also, but if there are very many people exposed to high levels, smaller contour intervals are recommended for tabulating the severe health effects.

As with the general adverse effects, it is desirable to quantify the exposure of individuals to different levels by a single number. A term similar to the level-weighted population may be calculated using the hearing loss function (eqn. 10) identified in the previous section. This would result in a hearing loss-weighted population, HWP, measured in terms of hearing loss, expressed as person-decibels:

$$HWP = \int_{75}^x P(L_{eq}(8)) \cdot H(L_{eq}(8)) \cdot d(L_{eq}(8)) \quad \text{Eqn. 11}$$

where $P(L_{eq}(8))$ is the population distribution as a function of 8-hour L_{eq} , $H(L_{eq}(8))$ is the weighting function given in equation 10 (and Figure 8 and Table 5), and $d(L_{eq}(8))$ is the differential change in 8-hour average sound level. Replacing the integrals by summations of successive increments in average sound level we have:

$$HWP = \sum P(L_{eq}(8))_i \cdot H(L_{eq}(8))_i \quad \text{Eqn. 12}$$

where i indexes the successive increments in average sound level. If the $L_{eq}(24)$ measure is preferred for a particular application, summation would start at 70 dB.

The disadvantage of the hearing-weighted population is that it is not easily understood: the product of persons and decibels of hearing loss is not an intuitively obvious concept. A more understandable indicator of

severe health effects is the average potential hearing loss (PHL) which is analogous to the noise impact index for general audible noise:

$$PHL = \frac{HWP}{P_{total}} = \frac{\sum P(L_{eq}(8))_i \cdot H(L_{eq}(8))_i}{\sum P(L_{eq}(8))_i} \quad \text{Eqn. 13}$$

where the terms are as defined for equation 12, and P_{total} is equal to the base population, which is normally the population exposed to levels above 75 dB. Care should be taken in defining the base population, however. If it is to be used to compare alternatives, the same base population must be used for all. Otherwise, the average hearing loss could be lowered by a project which affected more people, and the indicator would not be a reliable measure of impact. The simplest approach is to use as the base population the largest total population subjected to severe health effects by any of the alternatives. If this is done, PHL indicates the average hearing loss, in decibels, for those people subjected to severe health effects due to noise.

Again, the above equations may be replaced by a summation over successive increments of day-night sound level. It is recommended that increments of day-night sound level less than five decibels (i.e., preferably one or two decibels) be used in calculating values of PHL.

Further, analogous to the assessment of general audible noise, the change in hearing loss-weighted population is a useful descriptor for many assessment purposes, as is the relative change in impact defined in Equation 8 with HWP substituted for LWP.

2.4 Environmental degradation

Even in areas where no people are presently living, a significant increase in noise over existing conditions may constitute a noise impact. The

environment may be degraded either because the increased noise affects wild-life, or because it destroys the tranquility of a wilderness area to which urban dwellers wish to go for an escape from city noise, or because it makes the area unsuitable for future residential or other noise-sensitive development. In each case, some of the quiet which is one of our national natural resources is lost; the quality of the environment is lowered.

Unfortunately, there are no data available which express this reduction in environmental quality as a function of noise level, or of the change in noise level. Consequently, it is not possible to identify a special criterion function for these areas, such as those identified in sections 2.2.1 and 2.3.1.* Instead, quantification of environmental degradation normally proceeds only as far as the tabulation of the extent of the impact. The only modifications necessary for the standard tabulation (such as the example Tables 6 through 9) is the likely deletion of the columns on residential and employee populations, and a revision in the use of the special situations column. Animal species which are particularly vulnerable and recreational uses of the areas will be the principal kinds of special situations to be listed. As a supplement to this numeric quantification, a word description of the environmental impact should be provided in terms of the expected change from the present conditions, paying particular attention to the special situations. In some circumstances, it may be useful to reduce this tabulation to a single number, for example for comparisons or trade-offs with other planning criteria. In those cases, a "level-weighted area" can be calculated

*Reference 32 presents quantification methods for evaluating the noise impact in recreational or wilderness areas. The evaluation criteria contained in that report show a relationship between the detectability of sound sources and the acceptability of those sounds in various recreational use areas. This criteria is based on the experiences of U.S. Forest Service personnel.

by using the population weighting function of Table 3, which is the best available indicator of relative impact.

Rural areas can be treated by the methods of either this section or section 2.2. That is, the analysis can stop with the tabulation of impacts, or it can proceed to calculate the level-weighted population. The equation used (equation 2b) shows some adverse response to general audible noise at levels as low as 45 dB (L_{dn}). However, because the percentage responding adversely is so small--less than 0.5 percent below 48 dB - and the number of people in most rural areas is so low, the magnitude of the level-weighted population will usually be so small as to be of little help in environmental assessment. Although the single-number index can be used in such areas, it is not recommended as strongly for them as it is for urban areas.

2.5 Treatment of temporary projects

The major simplification in the analysis for temporary projects has already been mentioned (section 1.4.2): the fact that prediction of future population in the affected area is unnecessary. For temporary projects lasting more than one year, that is the only modification necessary.

For temporary projects, the same as for permanent noise environments, the yearly day-night sound level should be used in computation of impact indices. Impact assessment is done in the same manner as for permanent noise environments by the use of tabulations and calculation of the sound level-weighted population and noise impact index.

For temporary projects lasting less than a year, it is useful to compute the level-weighted population for two situations:

- (1) for the temporary noise environment as if it were permanent, but also stating its actual duration; and

- (2) for the temporary noise environment in terms of its contribution to the yearly day-night sound level.

For example, consider a population of 1000 experiencing a temporary day-night sound level of 70 decibels for nine months due to a construction project, after which the day-night sound level drops to 60 decibels on a long-term basis. The following two situations would be described.

1. During the nine-month construction period itself, the level-weighted population is $(0.245) (1000) = 245$ persons responding adversely to the noise.

2. To calculate the effect of the construction activity on annual average impact requires calculation of the yearly day-night average sound level:

$$L_{dn}(y) = 10 \log_{10} \frac{1}{12} (9 \times 10^{\frac{70}{10}}) + (3 \times 10^{\frac{60}{10}}) = 68.9 \text{ decibels} \quad \text{Eqn. 14}$$

The above equation is derived from equation A-5 in Appendix A. On the basis of this $L_{dn}(y)$, the level-weighted population, or the full-year during which construction takes place, is $(0.224) \times (1000) = 224$ persons responding adversely to the noise. Note that the number of people affected is higher when calculated using $L_{dn}(y)$ than it would be if calculated using the time-weighted average of impacts during and after the project. In this example, the LWP after project completion, calculated from the L_{dn} of 60 dB, is $(0.087) \times (1000) = 87$ people responding adversely. The time-weighted annual average is:

$$LWP = \frac{1}{12} (9 \times 245 + 3 \times 87) = 205 \quad \text{Eqn. 15}$$

which is slightly smaller than that calculated on the basis of $L_{dn}(y)$. In most cases, the other impacts of the construction project will be considered only for the project duration, in which case the first calculation indicated here is more appropriate.

2.6 Practical example

Sample tables to demonstrate the approach discussed in this chapter have been drawn up for a simple example, applying the basic principles presented in these guidelines. The example is based on the proposed expansion of a highway which runs through a suburban area, and is simplified to facilitate understanding of the suggested procedures. Details of the example are contained in Appendix E, which also contains an additional practical example. This section is intended primarily to provide samples of the appropriate tables. It does not cover all possible types of problems for which these guidelines are appropriate.

As discussed in section 2.2.2, a number of tables are usually helpful. The first table documents affected areas (i.e., the base population and base area) for future noise levels without the proposed project (Table 6); the second deals with project noise alone (Table 7); and the third tabulates effects for the project noise together with all other sources (Table 8). The final table provides details of various special situations, which may be particularly affected by noise (Table 9). At the bottom of Tables 6 to 8, several of the single number indexes are stated. By comparing the single-number indexes presented in Tables 6 and 8, we see that the anticipated change in impact is an increase of 111 more people responding strongly to the adverse effects noise has on them. Likewise, the expected increase in potentially severe health effects ($L_{dn} \geq 75$ dB) is in the range of 13 person-decibels.

TABLE 6
 SAMPLE DATA PRESENTATION:
 FUTURE NOISE LEVELS WITHOUT PROPOSED PROJECT

Yearly L _{dn}	Residential Population	Industrial/ Commercial Employees	Total Land Area (sq km)	Residential Land Area (sq km)	Industrial/ Commercial Land Area (sq km)	Special Situations (See Table)
>85	0	0	0	0	0	-
80-85	0	10	0.0156	0	0.0156	-
75-80	0	40	0.0469	0	0.0469	-
70-75	0	130	0.0625	0	0.0625	-
65-70	833	470	0.3125	0.1875	0.1250	-
60-65	1389	2840	0.8542	0.3125	0.5417	8
55-60	2778	510	0.7083	0.6250	0.0833	1,2,3,4,5,6,7
50-55	0	0	0	0	0	-
45-50	0	0	0	0	0	-
	5,000	4,000	2.0	1.125	0.875	

Level Weighted Population (LWP) = 501 people
 Noise Impact Index (NII) = 0.10
 Hearing-loss Weighted Population (HWP) = 0

67

TABLE 7
 SAMPLE DATA PRESENTATION:
 FUTURE NOISE LEVELS OF PROJECT ALONE

Yearly L _{dn}	Residential Population	Industrial/ Commercial Employees	Total Land Area (sq km)	Residential Land Area (sq km)	Industrial/ Commercial Land Area (sq km)	Special Situations (See Table)
>85	0	0	0	0	0	-
80-85	0	0	0	0	0	-
75-80	83	140	0.050	0.01875	0.03125	-
70-75	150	240	0.090	0.03375	0.05625	8
65-70	350	370	0.160	0.07875	0.08125	-
60-65	717	800	0.340	0.16125	0.17875	1,2
55-60	1200	1500	0.610	0.27000	0.34000	3,6
50-55	833	380	0.250	0.18750	0.06250	4,7
45-50	1667	570	0.500	0.37500	0.12500	5
	<u>5,000</u>	<u>4,000</u>	<u>2.000</u>	<u>1.12500</u>	<u>0.8750</u>	

Level Weighted Population (LWP) = 362 people

Noise Impact Index (NII) = 0.07

Hearing-Loss Weighted Population (HWP) = 13 person-decibels

Average Potential Hearing Loss (PHL) = 0.16 dB per person for 83 people

TABLE 8
 SAMPLE DATA PRESENTATION:
 FUTURE LEVELS FROM ALL SOURCES COMBINED

Yearly L _{dn}	Residential Population	Industrial/ Commercial Employees	Total Land Area (sq km)	Residential Land Area (sq km)	Industrial/ Commercial Land Area (sq km)	Special Situations (See Table)
>85	0	0	0	0	0	-
80-85	0	10	0.0160	0	0.0160	-
75-80	83	75	0.0969	0.01875	0.07815	-
70-75	150	240	0.1350	0.03375	0.10125	8
65-70	1278	640	0.44875	0.28750	0.16125	-
60-65	1128	2535	0.6971	0.25375	0.44335	1,2
55-60	2361	500	0.60625	0.53125	0.0750	3,4,5,6,7
50-55	0	0	0	0	0	
45-50	0	0	0	0	0	
	5,000	4,000	2.000	1.12500	0.8750	

Level Weighted Population (LWP) = 612 people

Noise Impact Index (NIL) = 0.12

Hearing-Loss Weighted Population (HWP) = 13 person-decibels

Average Potential Hearing Loss (PHL) = 0.16 dB per person for 83 people

TABLE 9
 SAMPLE DATA PRESENTATION:
 SPECIAL SITUATIONS

	Average Population		Area (sq km)	Comments
	Day	Night		
1. School	300	-	-	-
2. Playground	40	0	-	-
3. Park	30	0	-	-
4. Church	63	0	-	-
5. Nursing Home	200	200	-	-
6. School	1000	150	-	Night Classes
7. Library	25	5	-	-
8. School	500	-	-	-

CHAPTER 3
SPECIAL NOISES

Not all noises can be adequately evaluated by average A-weighted sound levels. Examples of the special noises which require other measurement systems are the following: (1) infrasound, in the frequency range of 0.1 to 20 Hz; (2) ultrasound, frequency range above 20 kHz; (3) certain types of impulse noises such as sonic booms and blasts; and (4) sounds that convey more information than random noise sources with comparable average sound levels, such as voices, warning signals, or barking dogs. This chapter contains a section discussing each of these four special noises. For the first three, the section discusses measurement, screening levels, and human effects. For the fourth, the section merely provides a brief description of the nature of the problem and of how it might be treated in a noise impact analysis.

3.1 High-energy impulse noise

The assessment of impulse noise presents unusual problems. In many cases the appropriate techniques and measures are applicable only to particular situations. (For example, with respect to blast noise, damage to certain types of buildings can be predicted in terms of non-acoustic parameters, such as effective distance and the amount of explosive charge.) Moreover, the significance of the noise impact cannot always be quantified for the same effects suggested for general audible noises. Whereas low-level impulse noise is accounted for as part of normal general audible noise, high-energy impulses require additional measurements for impact assessment. In many situations an individual interpretation of the criteria is required.

At present, high-energy impulse noise comes primarily from sonic booms, blasting operations, or artillery fire. Some limited community response data for sonic booms and artillery fire are available [33, 34]. Noise measurement instrumentation at the time of the sonic boom study (1965) was not as sophisticated as it is now, so the physical measures from that study (peak overpressure in pounds per square foot) need to be converted to more recently developed measures. Consequently, the methods presented in this section need to be verified with more data, some of which is being collected at the time of this writing. The methods presented here are based on the only available data [5], and should be applied with some caution.

3.1.1 Description of high-energy impulse noise

Day-night sound level is the primary descriptor for environmental noise. High-energy impulse sounds, such as those produced by sonic booms, quarry blasts, or artillery fire, in addition to the high-level audible sound, can excite noticeable vibration of buildings and other structures. These induced vibrations -- caused by airborne sound or transmitted through the ground or structures -- may generate additional annoyance beyond that due to simple audibility of the impulse, because of "house rattling" and "startle," as well as because of additional contributions to interference with speech or sleep. The annoyance data which are used in the next section to summarize community response to impulse noise are based on the annoyance caused by house rattle.

It has been general practice in the past to describe such high-energy impulse sounds in terms of the peak sound pressure level over a wide frequency band. While the peak pressure may be satisfactory for assessment of impulses in a restricted range of peak pressures and durations, it is not sufficient as a general descriptor for use in measurement or prediction of

the combined environmental effects of impulses having substantially different pressure-time characteristics. Use of the peak pressure is also unwieldy or misleading when a succession of impulses, sometimes overlapping, must be evaluated.

The noise measure recommended in these guidelines for assessing the environmental impact of high-energy impulse noise is similar to the measure used for general audible noise. This is the C-weighted day-night sound level, symbolized as L_{Cdn} . The L_{Cdn} , in turn, may be derived from individual impulse noise events described in terms of a C-weighted sound exposure level, L_{SC} .

There are two reasons for using a C-weighting. First, it does not discount the low frequency components which are a major part of impulse noise and of vibration, as the A-weighting network does. Second, subjective estimates of impulsive noise magnitude conform with magnitude estimates of other noises when the high-energy impulsive noise is measured by C-weighting and the other noises are measured by A-weighting [35]. In general, C-weighting has been found to closely relate to average human response to high-energy impulse noise [36].*

The use of sound exposure level is recommended to facilitate combination of data when more than one impulse noise event occurs per day, as is usually the case. Further, it is consistent with subjective evaluations of sonic booms where duration of the signal influences subjective response [38].

The assessment procedures suggested in this section should be used for impulse sounds that have daytime C-weighted sound exposure levels greater than

* For most situations, C-weighted sound exposure levels are adequate for assessing the impact of high-energy impulsive noise. However, for very low frequency noise events, such as confined blasts, C-weighted sound exposure level may not be as good as various lower frequency measures [37].

about 80 dB. This corresponds to unweighted peak sound pressure levels for sonic booms and confined mining blasts greater than about 106 dB, which appears to be the threshold of adverse community response on the basis of the data on sonic booms. This in turn corresponds to unweighted peak sound pressure for unconfined surface explosions and artillery fire of about 100 dB. At night, the threshold of response should be reduced to a C-weighted sound exposure level of 70 dB (corresponding to unweighted peak sound pressure levels of 96 dB and 90 dB for sonic booms and artillery fire, respectively), because of the decreased acceptability of nighttime impulsive exposures [33, p. 150]. Impulse events with lower levels than described above are assumed to elicit normal auditory responses and are assumed for most situations to be described adequately by L_{dn} . For very high level impulses with unweighted peak sound pressure levels greater than 140 dB, assessment criteria based on actual physiological or structural damage should also be applied. In addition, the effects of groundborne vibration should be assessed (Chapter 4).

In most cases where impulse noise needs to be considered, the task for the noise impact analysis is to predict or estimate in advance what the levels of impulse noise will be. With rare exceptions (e.g., reference 39), there are no reliable predictive techniques other than using a measurement of a similar event occurring elsewhere. When the only data available are expressed as peak sound pressure, useful approximations can be based on indications that L_{SG} is roughly 26 dB lower than the peak sound pressure level for both booms [40] and confined blasts, and 20 dB lower for unconfined blast noise and artillery fire [41, Fig. 29]. In those cases where it is possible to conduct measurements of a similar event elsewhere, it is important to be able to distinguish impulse noise (such as sonic boom) from other high-energy noise events (such as jet aircraft flyovers). A useful rule of thumb to aid in

making such a distinction is that for an impulse noise the maximum C-weighted sound exposure level in any 2-second time period is 10 dB greater than the C-weighted sound exposure level in any contiguous 2-second period of the event.

3.1.2 Human noise exposure effects of high-energy impulse noise

The Oklahoma City sonic boom study [33] and the artillery fire study [34] form the primary bases for the procedure proposed for assessment of the effects of high-energy impulse sounds. In the sonic boom study [33], eight supersonic overflights were performed daily for six months. Altitudes and airspeeds were selected to obtain three different nominal overpressures, on an increasing basis, during the tests. Personal interviews of respondents were made during three time periods that corresponded to the three different nominal overpressures. Interviews were conducted at three different distances from the ground projection of the flight path to obtain different exposures for each of the three boom levels.

The questionnaire structure and response scaling used in the sonic boom social survey are such that direct comparison with other surveys is difficult. The responses to a question on the degree of annoyance due to "house rattles" caused by the booms is used here as the primary measure to quantify community response. The category "serious" annoyance is considered to be most comparable to the highly annoyed response used (in section 2.2.1) to summarize the adverse effects of general audible noise. It should be noted that the percent of respondents reporting serious annoyance at different boom levels was not a percentage of the total population sample, but only of that fraction of the sample that believed it appropriate to complain about governmental actions. This fraction is of the order of 60 percent. To compare these responses to

the total populations used in other surveys, an adjustment for the total population was made in the current analysis.

The noise measurements in the sonic boom study were collected in terms of nominal peak overpressures. Conversion of nominal overpressures to C-weighted sound exposure levels were made using the average difference of 26 decibels between peak overpressure and C-weighted sound exposure level. The resulting values were then used to compute L_{Cdn} for the eight daytime sonic booms, using the approximation:

$$L_{Cdn} = L_{SC} + 10 \log (N_d + 10 N_n) - 49.4 \quad \text{Eqn. 16}$$

where N_d and N_n represent the number of impulse events during the day and night, respectively. Thus for eight sonic booms per day, equation 16 reduces to:

$$L_{Cdn} = L_{SC} - 40.5 \quad \text{Eqn. 17}$$

The resulting data for the percent highly annoyed at the computed C-weighted day-night sound level values are plotted as filled-in squares in Figure 9.

In the artillery fire study [34], groups of residents were interviewed at nine sites in the vicinity of an Army base where extensive artillery firing training takes place. Six of the sites that were off-base are considered here. Noise monitoring on a 24-hour basis took place at 17 locations for an average of approximately 25 days per site. These measured average sound levels in conjunction with computer based predictive models were used to obtain annual average C-weighted day-night average sound levels for artillery noise associated with the environments in which the survey respondents lived. The social survey used scales similar to other recent surveys. The percent

DEPT ARMY AVIATION LAB

of respondents reporting high annoyance are plotted as filled-in circles on Figure 9.

Using annoyance data from both the Oklahoma City sonic boom study and the artillery fire study, a function is plotted in Figure 9 which shows a reasonably good fit of projected high annoyance against C-weighted day-night sound levels. Over the range of data available, the function illustrated in Figure 9 provides a reasonably good prediction of the percentage of the population who can be expected to be highly annoyed at given exposures to high-energy impulse noise. Consequently, it is proposed to use the function shown in Figure 9 and presented in equation 18 below* for the assessment of high-energy impulse noise, despite the fact that such applications may need to extrapolate beyond existing data.

$$\% \text{ HA} = \frac{100}{1 + e^{(11.17 - 0.153 L_{\text{Cdn}})}} \quad \text{Eqn. 18}$$

Quantification of adverse human response anticipated from high-energy impulse noise is performed in the same manner as for general audible noise (Section 2.2.2). The appropriate weighting function describing the population exposed to high-energy impulses who are highly annoyed with the noise may be computed from equation 18, or read from Figure 9 or Table 10. Level-weighted population may then be computed from equation 6. Likewise, Noise Impact Index and Relative Change in Population may be calculated from equations 7 and 8, respectively.

In many situations, both impulse noise (measured in L_{Cdn}) and general audible noise (measured in L_{Adn}) will be of concern, and it will be necessary

*Note that the format of equation 18 is similar to that footnoted on page 36 in section 2.2.1.

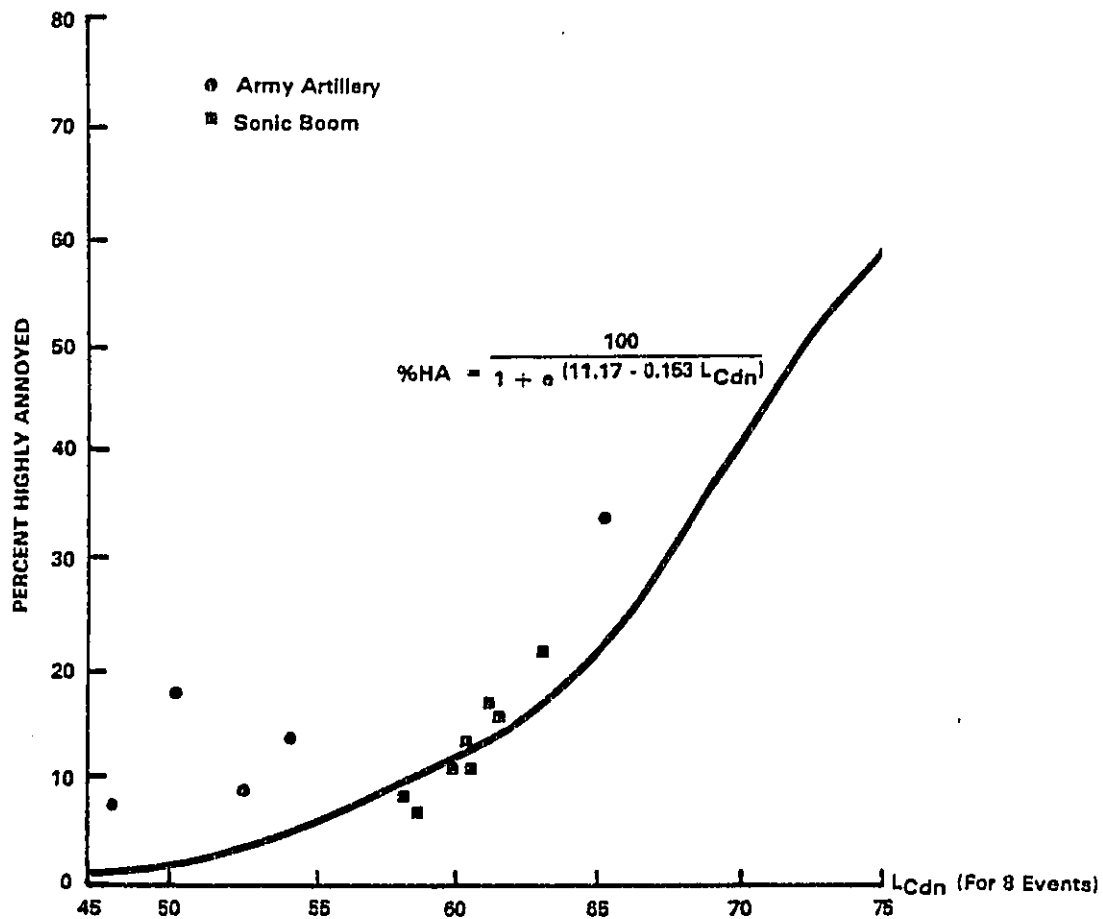

**FIGURE 9. RECOMMENDED RELATIONSHIP FOR PREDICTING
 COMMUNITY RESPONSE TO HIGH ENERGY
 IMPULSIVE SOUNDS (Source : Reference 5)**

$$L_{Cdn} = L_{pe} + 10 \log (N_d + 10 N_n) - 40.4$$

$$L_{pe} = L_{ps} - 28 \text{ (for sonic booms and confined blasts)}$$

$$L_{pe} = L_{ps} - 20 \text{ (for artillery fire and unconfined blasts)}$$

TABLE 10

VALUES OF WEIGHTING FUNCTION FOR HIGH ENERGY IMPULSE NOISE

 $[W(L_{Cdn}) = (0.01)\% HA]$

L_{Cdn}	$W(L_{Cdn})$
45	0.014
46	0.016
47	0.018
48	0.021
49	0.025
50	0.029
51	0.033
52	0.039
53	0.045
54	0.052
55	0.060
56	0.069
57	0.080
58	0.091
59	0.105
60	0.120
61	0.137
62	0.157
63	0.178
64	0.201
65	0.227
66	0.255
67	0.285
68	0.317
69	0.351
70	0.387
71	0.424
72	0.462
73	0.500
74	0.538
75	0.576

somehow to combine the results to obtain a total number of people affected by all aspects of the noise. An assessment of the overall noise environment, combining the effects of high-energy impulse sounds and of general audible noise, can be made by equating the degree of annoyance expected from the two types of noise sources. Using Figures 4 and 9, then, it is possible to identify a specific C-weighted L_{Qdn} which causes as much annoyance as an A-weighted day-night sound level. For example, an L_{Qdn} of 65 dB is expected to result in 23 percent of the exposed population being highly annoyed by the noise (Figure 9). This same level of annoyance is reached at an A-weighted day-night sound level of 69 dB (Figure 4). Thus the L_{Qdn} may be converted to L_{dn} via equal annoyance (Table 11). This converted L_{dn} is added, logarithmically, to the general audible noise already measured in terms of L_{dn} , and the resulting composite noise level is used for assessment of the overall noise environment, using Figure 4 and Table 3 as necessary. This procedure is performed in order to avoid the double-counting of affected people which could result if they were tallied separately for impulse noise and for general audible noise.

3.1.3 Structural damage criteria for impulse noise

It is normally considered that the most sensitive parts of a structure to airborne noise or overpressure are the structure's windows, although in some cases it may be plastered walls or ceilings. Such noise or large pressure waves also introduce building vibration in addition to that due to ground motion. Thus the effects of airborne sound on structures may need to be evaluated in terms of vibration criteria as well as in terms of criteria based on peak overpressure. For most airborne sound, however, evaluation of the peak overpressure is sufficient to determine the threshold of possible damage.

TABLE 11
 CONVERSION OF L_{Cdn} TO L_{dn} VIA EQUAL ANNOYANCE

<u>L_{Cdn}</u>	<u>% Highly Annoyed</u>	<u>L_{dn}</u>
45	1	45
46	2	49
47	2	49
48	2	49
49	3	52
50	3	52
51	3	52
52	4	54
53	4	54
54	5	56
55	6	57
56	7	58
57	8	59
58	9	60
59	10	61
60	12	63
61	14	64
62	16	65
63	18	67
64	20	68
65	23	69
66	25	70
67	28	72
68	32	73
69	35	74
70	39	76
71	42	77
72	46	78
73	50	79
74	54	80
75	58	81

On the other hand, for some types of underground blasting and when the building is close to the blast site, the vibration is transmitted essentially through the ground. In this case the vibration inside the house must be predicted and evaluated according to the vibration criteria (Chap. 4). This subsection describes structural damage criteria for three kinds of impulse noise: blast noise; sonic boom; and artillery fire. A brief paragraph is appended relating to structural damage from continuous sounds.

For blast noises, the probability of broken windowpanes should be estimated. Empirical formulas given below allow an estimate of "safe" distances from the blast, beyond which window damage is negligible. These formulas include sufficient safety factors to account for the negative influence of such variables as wind direction, atmospheric temperature gradients, and windowpane shape and size. These formulas are newly proposed and are somewhat tentative [42]. They are suggested here essentially as screening tools: if these equations suggest there will be no structural problems for a particular project, the impact analysis needs to proceed no further. If these formulas suggest a potential impact of blast noise on structures, then the analyst (or blasting engineer) should undertake a more detailed analysis which involves explicit consideration of the variables covered by a safety factor in these formulas. It should be noted that the relationships expressed in these formulas may not be applicable at distances of less than 1 km between the blasting activity and the nearest residence depending upon situational factors. For these cases, direct air blast monitoring is recommended to assure that excessive noise levels are not reached.

For surface explosions, window breakage in residential type structures is expected to be negligible (less than 50 percent probability of even one broken

DEPT. OF ENVIRONMENTAL AFFAIRS

pane) if the charge per delay equivalent weight* of high explosive (WHE) in kilograms is less than that specified by the more appropriate of the following two conditions:

- (1) If the population is non-uniformly distributed, but is clustered, then each population cluster, including the nearest residence, should be checked. The amount of WHE for any cluster should be less than $328 R^3/N$ where R is the distance in kilometers from the explosion to the center of a cluster of residences and N is the number of people residing in that cluster with the provision that N must always be at least 4 (assumed number of people per house).
- (2) If the population is reasonably uniformly distributed, then the amount of WHE should be less than $40 R^3$, where R is the distance in kilometers to the nearest residence.

The use of these formulas requires some judgment as to what constitutes a population cluster and what constitutes a reasonably uniform distribution. In some cases, both formulas might be checked and the one that predicts the least allowable amount of WHE used.

For explosives buried deeper than 1.4 meter per $(Kg)^{1/3}$, the peak amplitude will be attenuated by at least a factor of 5**. For such underground explosions the preceding formulas need to be adjusted as follows:

- (1) Population clusters - the amount of WHE should be less than $26430 R^3/N$.
- (2) Uniformly distributed population - the amount of WHE should be less than $3200 R^3$.

*Weight per detonation where each detonation is delayed to go off in a predetermined sequence (usually within a fraction of one second) for each event. The duration of the total event is normally less than one second.
**The factor of 5 is based on effects at large distances. At short distances this may range to a factor of 15 or even higher.

For explosive charges greater than those determined by the above formulas, the peak overpressure should be predicted and the number of broken windows estimated. The statistical estimator (Q) for the number of "average typical" panes broken is:

$$Q = 1.56 \times 10^{-10} N(PK^*)^{2.78} \quad \text{Eqn. 17}$$

where N = number of people exposed (assuming 19 panes per person) and PK* is the peak-to-peak amplitude of the pressure variation (in pascals) at ground level. The conversion between the peak free air pressure (ΔP) and PK* is given by the relation:

$$PK^* = 2.7 \Delta P \quad \text{Eqn. 18}$$

However, the peak pressure may be amplified by a factor of 5 as the result of atmospheric refraction, ducting, and focusing; therefore, in the "worst case" condition the number of broken panes, Q, may be multiplied by a factor as high as $(5)^{2.78}$ or 88 to obtain Q_{\max} . In addition, for peak pressures (ΔP) above 140 dB (200 Pa), structural damage other than window damage may occur. Measurement or prediction of vibration should be accomplished.

For sonic booms, mining blasts, and artillery fire, the amount of window damage can be estimated by calculating Q and Q_{\max} for the expected peak pressure, as discussed for blasts. These formulas, however, should be used only for peak pressure levels above 130 dB. Above 140 dB, structural damage should also be assessed by prediction or measurement of vibration levels in the exposed structures.

For continuous sounds above sound pressure levels of 130 dB, there is the possibility of structural damage due to excitation of structural resonances for infrasound, as well as low and medium frequency sound. While

certain frequencies (such as 30 Hz for window breakage) might be of more concern than other frequencies, one may conservatively consider all sound lasting more than 1 sec above a sound pressure level of 130 dB (1 Hz to 1000 Hz) as potentially damaging to structures.

3.2 Infrasound

3.2.1 Description of infrasound

Infrasound is defined as sound in the frequency range below about 20 Hz. The measurement of infrasound should be made with instrumentation having a flat frequency response (± 3 dB) from 0.1 Hz to 1000 Hz. The reason for the extended measurement range is that in evaluating a noise that is composed of both infrasound and higher frequency sound, the higher frequency sound must also be measured for proper assessment of the infrasound, because sounds above 20 Hz can mask the infrasonic sounds.

Although blasting operations cause infrasound as well as impulse noise and vibration, it is not intended that all of these analyses be conducted. Among other considerations, the necessary instrumentation is different for each of these special noises. For blasting, an impulse noise evaluation is adequate, covering both human and structural effects. Because infrasound can be related to vibration, the vibration analysis (Chap. 4) also helps reduce any need for a special infrasound analysis.

3.2.2 Human noise exposure effects of infrasound

On the basis of a summary of infrasound effects (Figure 10), compiled from the Levels Document [2] and more recent work [43, 44], it is suggested that for exposures of less than 1 minute the maximum sound pressure level should be below the following values:

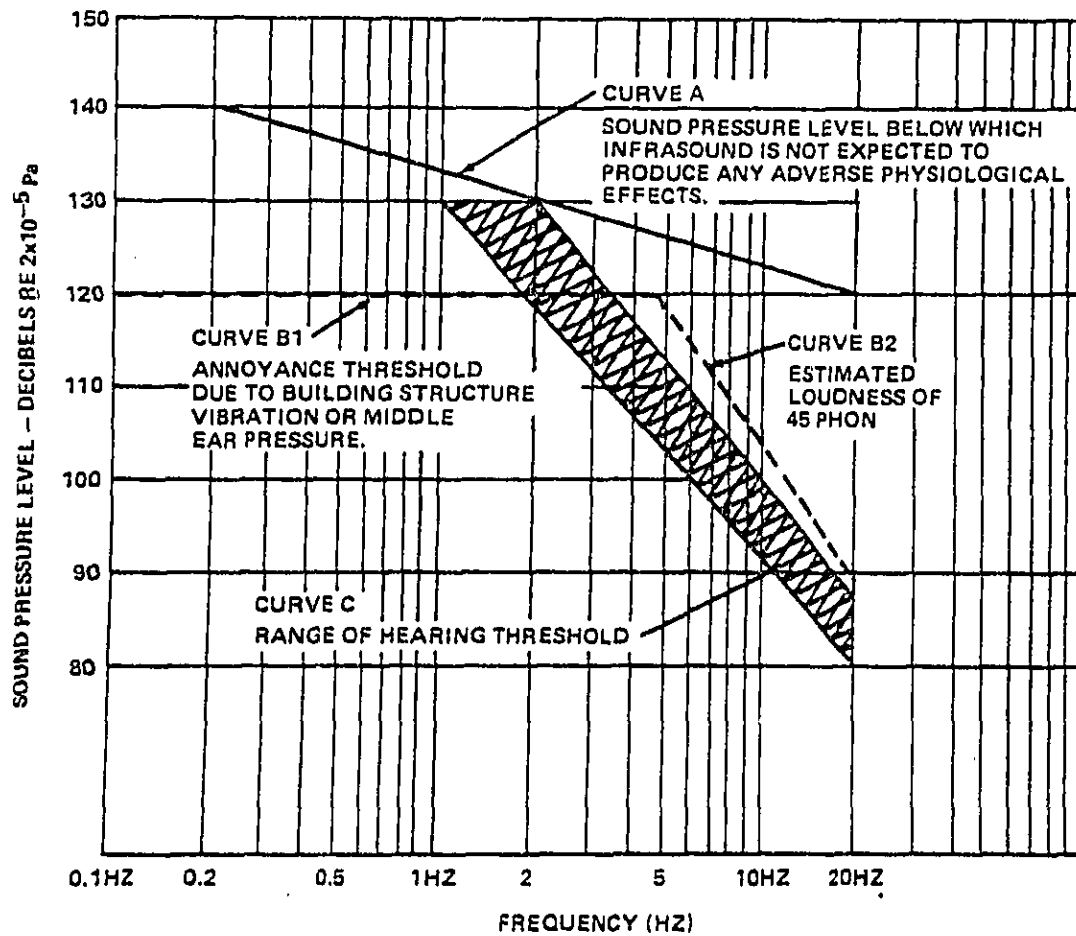

FIGURE 10. INFRASOUND CRITERIA

0.1 Hz to 5 Hz . . . 120 dB

5 Hz to 20 Hz . . . $120 \text{ dB} - 30 \log \frac{f}{5}$ Eqn. 19

where f is the dominant frequency. For exposures longer than 1 minute and less than 100 minutes, the levels should be reduced by $(10 \log t)$ dB where t is time of exposure in minutes. Exposure longer than 100 minutes should use the 100 minute limits. In other words, exposures 20 dB less than the one-minute criterion should be regarded as having no impact, regardless of exposure time. The 100-minute criterion basically insures that the infrasound is inaudible. These levels serve essentially as screening levels. As long as they are not exceeded, infrasound does not need to be included in the noise analysis.

For evaluating the impact, if this screening criterion is exceeded, a single-number index is not suitable. Instead, the impact should be qualitatively described; the effects that might occur at different sound levels are given in Figure 10. Any assessment of the effects beyond those in Figure 10 is not contained in these guidelines and will require further research and investigation.

3.3 Ultrasound

3.3.1 Description of ultrasound

Ultrasound is defined as sound at frequencies between 20 kHz and 100 kHz. Seldom is ultrasound an environmental problem and, unless the level is expected to exceed 105 dB, it can be ignored in an environmental noise analysis.

Measurement of ultrasound should be accomplished by instrumentation with flat response (± 3 dB) from 10 kHz to 100 kHz.

3.3.2 Human effects of ultrasound

Ultrasound noise levels below 105 dB (frequencies above 20 kHz) are considered to have no significant impact on people. Noise levels above 105 decibels should be reported in the analysis and individually evaluated based on specific research studies. In particular, studies of effects on animals may be important. No further quantification of the environmental impact of ultrasound is recommended. Rarely is ultrasound (except for some occupational situations, e.g., ultrasonic cleaners) an environmental problem of practical interest. Evaluation of ultrasound exposure above 105 dB requires additional investigation and research.

3.4 Noises with information content

Some general audible noises are also more annoying than their level alone would indicate, due in part to their information content or clear detectability. Examples include barking dogs and back-up alarms, but the primary problem is voice communication (live, amplified or recorded) that crosses residential boundaries at high levels. There is no formal method for assessing the impact of such sounds; each case must be assessed on its particular merits. It is recommended, however, that the analyst mentions how, as a result of the proposed action, the intrusion of understandable voices into some area might cause loss of privacy and consequent undesirable effects. The actual content of the typical messages or words might be stated along with the number of people that are impacted.

CHAPTER 4

VIBRATION

This chapter contains procedures for evaluating the impact of vibration on man. While the main reason for their inclusion here is to account for vibration generated by airborne noise, the impact of certain types of vibration can be assessed whether the transmission paths are airborne or structure-borne. The two sections of this chapter deal with the human effects of vibration (Section 4.1) and the structural effects of vibration (Section 4.2).

The material in the first section is based on an approved ISO standard and its proposed amendments [45], and its United States Counterpart [46, 47]. These are summarized in Appendix D, to provide the necessary background to follow the recommendations in section 4.1. The recommendations in section 4.2 are based on consideration of that material and data contained in Bureau of Mines Bulletin 656 [48] and Report 8507 [49].

4.1 Human effects of vibration

Vibration of structures may be due to airborne acoustical waves or solid-borne vibration. Most problems caused by airborne impulse noise, when building vibrations are caused as a side effect of the primary auditory stimulus, should be accounted for by the procedures of section 3.1. Nevertheless, at certain times it may be necessary to assess separately the vibration caused by such sources. Groundborne vibration which is quite likely to accompany some mining, construction, and other industrial activities usually requires special evaluation. A method to evaluate human response to vibration inside buildings is presented which should be used to evaluate the impact of such activities. The method applies to the frequency range between 1 Hz and 80 Hz.

4.1.1 Description of building vibration

In those cases where vibration impact needs to be considered, the task for the noise impact analysis is to predict or estimate in advance what the levels of vibration will be. However, there are no reliable predictive techniques to estimate magnitude of vibration. Therefore, it is suggested that, if possible, a similar event be measured elsewhere.

For continuous vibration environments, rms acceleration should be measured along three orthogonal axes, one axis of which is normal to the surface being measured. The acceleration should be weighted to account for the dependence of human reaction on frequency by use of a low pass filter with a corner frequency of 5.6 Hz (Figure 11). This accounts for the fact that human sensitivity to acceleration decreases over the frequency range under consideration; above 10 Hz this decrease is approximately proportional to frequency. The assessment of the impact should be against greatest acceleration on any of the three axes used.

For building measurements to be appropriate for the criteria of the next subsection, the measurements should be taken on the floor at a point that has the maximum amplitude of all the reasonable points of entry of the vibration to the human occupants. Normally this point may be assumed to be at the mid-span or center of a room.

For impulsive shock the measurement should be the same as for the continuous vibration measurement, except that the peak acceleration, not the rms value, should be used. The duration for impulsive shock excitation will be determined by either the time the acceleration of an event exceeds 0.01 m/sec² or by the time the acceleration is within one-tenth of the peak value. Whichever gives the shorter duration should be used.

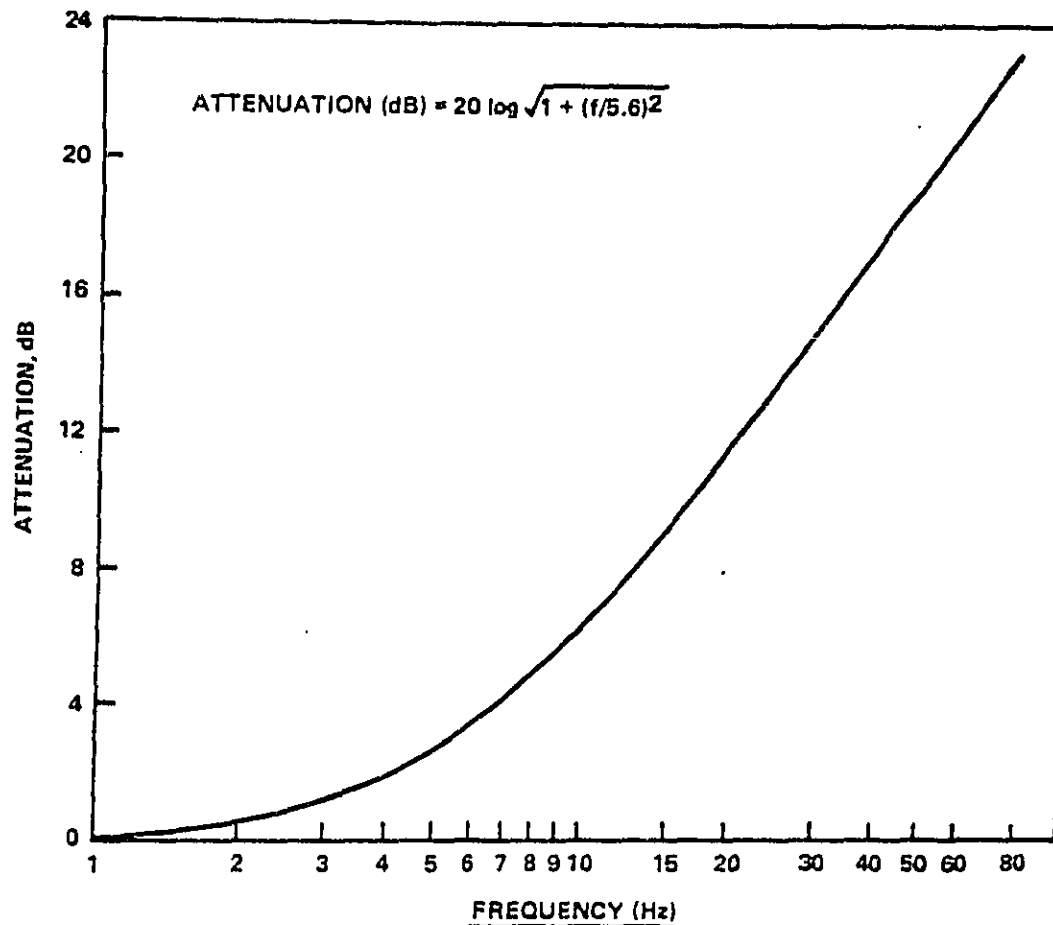

FIGURE 11. WEIGHTING CHARACTERISTIC FOR BUILDING VIBRATION IN TERMS OF HUMAN RESPONSE FOR THE FREQUENCY RANGE 1 TO 80 Hz.

Note: Electrical network for low frequency cutoff below 1 Hz and high frequency cutoff above 80 Hz not yet standardized.

4.1.2 Human vibration exposure criteria

Threshold levels are presented in Table 12 for most types of structures. Not all types of buildings are classified, but common sense should suggest the most appropriate classification.

The overall vibration that will not cause an adverse impact* for any condition and time period corresponds to rms acceleration values below $3.6 \times 10^{-3} \text{ m/s}^2$, evaluated by means of the weighting described in Figure 11. For hospital operating areas and other such critical areas, no higher levels should be permitted without analysis and justification of the acceptability of such levels.

TABLE 12

BASIC THRESHOLD ACCELERATION VALUES* FOR ACCEPTABLE VIBRATION ENVIRONMENTS

Type of Place	Time of Day	Continuous or Intermittent rms Acceleration (m/sec ²)	Impulsive Shock Excitation Peak Acceleration (m/sec ²)
Hospital Operating Rooms and Other Such Critical Areas	Day	0.0036	0.005
Residential	Night	0.0036	0.005
	Day	$\frac{0.072}{t}$	$\frac{0.1}{N}$
Office	Night	0.005	0.01
	Anytime	$\frac{0.14}{t}$	$\frac{0.2}{N}$
Factory and Workshop	Anytime	$\frac{0.28}{t}$	$\frac{0.4}{N}$

*Weighted as shown in Figure 11.

t = duration seconds of vibration, for durations greater than 100 sec, use t as 100 sec.

N = is the number of discrete shock excitations that are one sec or less in duration. For more than 100 excitations, use N = 100.

Daytime is 7 am to 10 pm. Nighttime is 10 pm to 7 am

*Insofar as structural damage is concerned, special caution is needed below 4 Hz [49].

For residential and other similar areas, continuous acceleration of greater values are normally expected to cause virtually no complaints (less than 1 percent). Even greater acceleration values could be permitted for shorter times during the daytime (0700 to 2200 hours), as indicated by Table 12 and by Figure 12. These also indicate that the maximum value of the impulsive shock excitation that is expected to cause virtually no complaints can be raised, dependent on the number of such impulses during the daytime. For residential areas or other areas where people sleep, the nighttime peak acceleration should be less than 0.01 m/sec^2 at any time and the continuous rms acceleration should be below 0.005 m/sec^2 if no complaints are to occur. No differentiation is made as to the types of residential areas, i.e., city center, urban or rural.

For office type spaces, the threshold at which no adverse effects occur is twice the daytime residential rms or peak value. No distinction is made between daytime and nighttime exposure.

For factory and similar type spaces, the threshold at which no effects occur is 4 times the daytime residential values. No distinction is made between daytime and nighttime exposure.

Offices and workplaces may in many cases require vibration levels as low as residential areas if any adverse reactions are to be avoided. In certain critical areas, such as operating rooms and laboratories and possibly research laboratories, standards rooms, tool rooms and the like, even lower vibration exposures levels may be required than indicated by Table 12.

The acceleration values that are specified to cause less than 1 percent complaints are near or at the perception threshold level of vibration during normal activity and should serve as a realistic threshold of any adverse reaction to the vibration. The percentage of complaints likely to occur

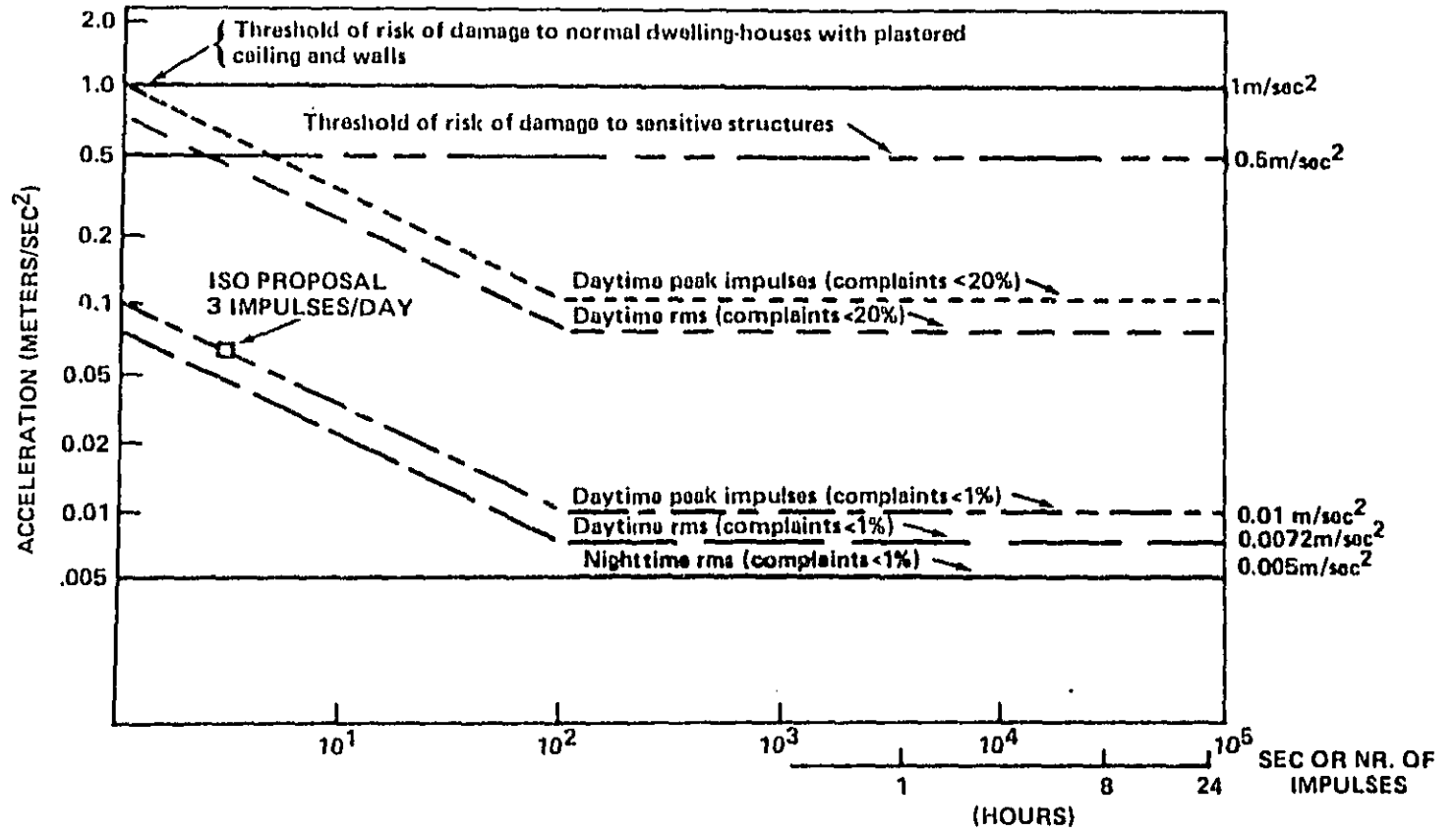

NUMBER OF IMPULSES PER DAY OR EXPOSURE TIME
FIGURE 12. VIBRATION CRITERIA FOR RESIDENTIAL AREAS

for higher levels of vibration are shown in Figure 13, which summarizes the complaint history from the Salmon Nuclear Event [48]. For a single event the number of complaints for residential areas varies roughly as $10 \log K$ (for peak acceleration range of 0.1 m/sec^2 to 1.0 m/sec^2), where K is the ratio of the observed acceleration to 0.1 m/sec^2 .

4.1.3 Quantification of the impact

There is a lack of data related to the assessment of the severity of the impact that results if the vibration guidelines proposed in this section are exceeded. It is recommended that the number of people exposed to vibration levels above the "no complaint" value (Table 12) be estimated. For a specific action, therefore, contours of the appropriate "no complaint" acceleration values as determined by Table 12 should be predicted or measured. For example, if an action causes a steady vibration that lasts a total of 25 seconds a day (during daytime hours), the contour of 0.014 m/sec^2 should be evaluated ($0.072 / 25 = 0.014$).

In addition to the mapping and tabulation of the impact, which cover sensitive non-residential as well as residential buildings, single-number indexes can be calculated which are similar to those suggested for general audible noise (the level-weighted population and hearing-weighted population). These indexes are based on the relationship for the percent complaining, documented in Figure 13. It is suggested that this concept be tentatively broadened to apply the vibration exposure to more than one impulse or to intermittent/continuous exposures by using the ratio (k) of the actual acceleration to the recommended "no complaint" acceleration value. A term for the impact of vibration on residential areas can then be defined by using a vibration weighting function. This function is described by:

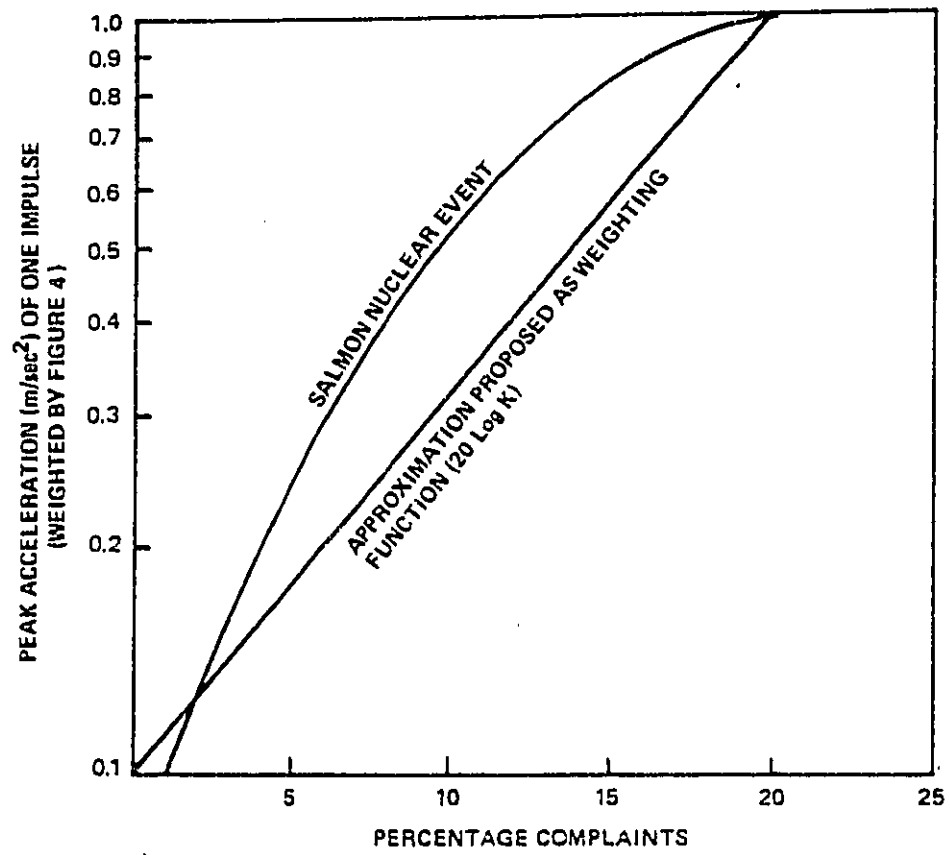

Figure-13. Percentage of Population Complaining as a Function of Peak Acceleration (Source: Reference 48)

$$V(k) = 20 \log k$$

Eqn. 20

where k is the ratio of the actual acceleration to the recommended "no complaint" acceleration values listed in Table 12 for a specified time period, and where k is limited to values from 1 to 20.

This function can be used to calculate a descriptor of the total vibration impact of a project, by multiplying the number of people exposed to each vibration condition by the vibration weighting function for that condition, and then finding the sum of these products. This Vibration-Weighted Population (VWP) is defined as:

$$VWP = \int_1^k P(k) V(k) dk$$

Eqn. 21

where $V(k)$ is the vibration weighting function described above, $P(k)$ is the population distribution function, and dk is the differential change in k . An index, similar to the Noise Impact Index, but applied to vibration, is called the Vibration Impact Index (VII) and is calculated as:

$$VII = \frac{\int_1^k P(k) V(k) dk}{\int_1^k P(k) dk}$$

Eqn. 22

where the denominator is based on the alternative affecting the largest number of people. In other words, the base population for calculating the vibration impact index needs to be constant across alternatives for the number to be meaningful. Given that restriction, then changes in VWP and VII can both be used to evaluate various alternatives and actions with respect to vibration. The change can also be discussed by listing the expected effects at the nearest residence.

4.2 Structural effects of vibration

A structural vibration velocity of 2 in/sec has commonly been used as the safe limit, and certainly vibrations above this value will have a very adverse environmental impact. Note that, except for frequencies below 3 Hz, if the acceleration measured with the weighting network of Figure 11 is less than 1 m/sec², then the velocity will be 2 in/sec or less. For frequencies from 10 Hz to 80 Hz a weighted acceleration of 1 m/sec² is essentially equivalent to a velocity of 1 in/sec. In most practical cases, in which the acceleration is made up of several frequency components, an acceleration of less than 1 m/sec² will also mean that the resultant velocity will be less than 2 in/sec, and possibly less than 1 in/sec, regardless of frequency. Therefore, it is recommended that 1 m/sec² be used as the normally safe acceleration with respect to structural damage. Vibrations above this should be avoided, or special arrangements should be made with the owners of the exposed structures. Since some minor damage has occasionally been reported at vibration as low as 1 in/sec, (0.5 m/sec² to 1 m/sec²), exposures in the range between 0.5 m/sec² and 1 m/sec² should also be regarded as a potentially adverse exposure with respect to structural damage. Finally, the safe peak acceleration for ancient monuments or ruins should be considered as 0.05 m/sec². Higher exposure values for such ancient structures should not be considered safe without a detailed structural analysis.

No single-number index is suggested for summarizing the structural effects. Quantification of the impact will consist of a contour map and tabulation, showing the number of structures above the potentially damaging accelerations of 1 m/sec² and 0.5 m/sec². A description of the expected damage and the likelihood of such damage occurring should be provided for each type of structure. The information in Appendix D will be of some help

DEPT FORN AFFAIRS

in making this assessment, but sufficient data will not often be available to make this assessment fully. In such cases, a program for monitoring the actual damage, or lack of it, may be necessary.

CHAPTER 5

SUMMARY OF NOISE IMPACT ANALYSIS

This chapter provides an overview of the analysis that might be expected to characterize noise impact fully, by summarizing the preceding chapters. In addition, Figure 1 and Table 1 provide useful overviews of the kinds of analyses suggested.

5.1 Purpose and structure of the guidelines

These guidelines contain procedures which can be used to describe and quantify the noise-related impacts of proposed projects. The resulting description of noise impacts is intended to be easily understood by those making decisions, so that consideration of these impacts can be an integral part of the decision. The approach described here is applicable to any situation calling for the evaluation of noise-related impacts, such as EIS or environmental assessment preparation for the NEPA process, and is consistent with noise evaluation procedures used by FAA, FHWA, and HUD, among others. The approach is not mandatory, but is meant to complement these other procedures by showing how to proceed to a quantitative description of impacts on people (which is the ultimate goal of all procedures) from information on noise levels (which those procedures require).

These guidelines provide procedures for arriving at qualitative, tabular, and single number descriptions of noise environments. The quantitative approaches rely on tables detailing the affected area or population, and on a modification of the earlier fractional impact method [50] to reduce the tabulated information to a single number index. These descriptions should be applied to future as well as to immediate impacts.

Three principal types of noise environments are covered: general audible noise; special noises; and vibration. There is a separate chapter for each, which covers (1) the appropriate physical measurement, (2) methods for predicting that measure for the proposed project and for determining the existing levels, (3) human noise exposure criteria, and (4) procedures for quantifying impact. Within the chapter on general audible noise, three subsections are provided, entailing different approaches for human exposure criteria and quantification procedures in different noise ranges: urban and suburban settings (L_{dn} usually 55 to 75 dB); projects producing L_{dn} greater than 75 dB; and rural and wilderness areas (L_{dn} usually less than 55 dB).

Additional types of proposed actions for which these guidelines will be useful are projects which entail new populations to be introduced into noisy areas, and actions which are intended to reduce noise. The impact of temporary projects may be evaluated using a more simplified analysis. For all impact analysis, the necessary estimation and prediction entail uncertainty. When possible, the degree of uncertainty should be specified. In some circumstances, optimistic and pessimistic forecasts can be used to bracket the estimate.

5.2 Analysis of impacts of general audible noise

General audible noise is noise as commonly encountered in the environment. Therefore, the material in chapter 2 should cover the great majority of situations in which an evaluation of noise impacts is desired. The primary measure of general audible noise is L_{dn} , and whenever possible, an approximation to the annual average value should be used. In some cases this measure is inappropriate, and shorter term measures such as 1-hour L_{eq} or the sound

exposure level should be used. The screening diagram (Figure 3) shows that whenever the noise level after the project will be greater than the existing level a noise analysis is necessary (i.e., when the existing level is less than 10 dB greater than the project noise level). The diagram applies to both permanent and temporary projects.

Depending on the approximate range of L_{dn} values, different types of noise effects are of concern, and therefore different analyses are needed (Figure 14). At levels generally encountered in populated areas (approx. L_{dn} values of 45 dB to 80 dB), the general health and welfare effects of noise are the primary concern. At levels above 75 dB (8-hour L_{eq} at-ear) severe health effects become important. The threshold level at which these should be investigated is an L_{dn} of 75 dB. In rural or wilderness areas, with very low residential populations, environmental degradation is as much a concern as the effect of noise on residents. In such areas, judgment will have to be used in deciding between a health and welfare analysis and an environmental degradation analysis, depending more on characteristics of the area than on the existing or project noise level.

Regardless of which noise effects are the focus, two elements are always recommended for describing the impact. The first is a table (or set of tables) setting out the number of people and total area affected as a function of different noise levels. Five decibels is usually an appropriate interval to use for those tables. The second element is a verbal, qualitative description of the principal components of the impacts identified in the tables.

For general health and welfare effects and for severe health effects the quantitative analysis can proceed further, to calculate a single-number index which summarizes all the impacts. The human noise effects information discussed in the Levels Document applies in the general health and welfare

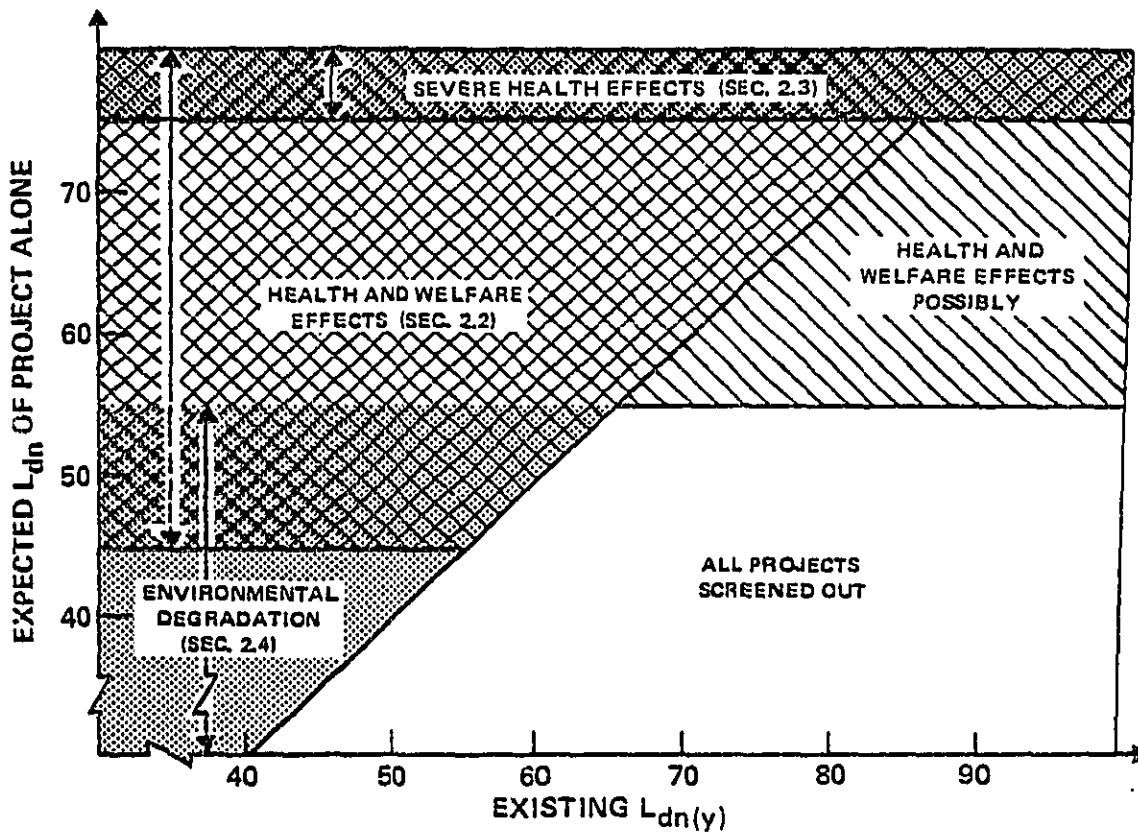

FIGURE 14. TYPES OF ANALYSES SUGGESTED

effects range: speech interference, sleep interruption, annoyance, and possible health effects. Given the existence of Schultz's synthesis [6], it is appropriate to use the percent of people who report being highly annoyed as the indicator of general adverse response, and to use his equation to summarize the total impact of noise on residential areas in terms of the number of people responding adversely to the noise. In the severe health effects range, the human noise exposure effects may include cardiovascular effects and other stress-related health problems. It is not known yet at what levels these begin to occur, but it is known that at an 8-hour L_{eq} of 75 dB hearing damage (NIPTS) begins to occur. The curve for average NIPTS versus $L_{eq}(8)$ is used as the function to reduce tabulated data for these extreme levels to a single-number indicator, because it is the only direct health effect for which such a function has been established.

5.3 Analysis of impacts due to special noises

The special noises discussed in this document are impulse noise, infrasound, ultrasound, and noises with information content. Effects on humans, structures, and animals all need to be considered.

For any special noise, the main task is to describe the noise environment for the population. As with general audible noise, tables such as those in Chapter 2 may be needed. Except for large impulse sounds, only a verbal, qualitative description of the effects of the special noise is recommended. The criteria of Chapter 3 should be cited, but in many cases additional documentation may be required. A discussion of previous experience with such noises should be made, if possible. For high-energy impulse noise, the analysis can be carried further and the expected percent highly annoyed, and changes in this quantity, can be estimated.

For structures exposed to impulse noise, the noise environment should be described for each building or set of buildings in terms of maximum sound pressure levels. Either a worst case or a statistical estimate of the distribution of maximum levels should be provided. A discussion of possible structural damages is required. The chance that such effects could occur should be estimated. Finally, the significance of such damage, in monetary and/or non-monetary terms, should be estimated.

5.4 Analysis of impacts due to vibration

If people are exposed, the analysis should include documentation of the vibration environment such that the expected vibration acceleration values due to the action are provided for all residential and other sensitive areas in which the weighted acceleration exceeds the "no complaint" level (Table 12). The change in the vibration environment can be discussed both by using the average Vibration Impact Index for the exposed population and by listing the expected effects at the nearest residence. A discussion of the effects of the vibration environment on sensitive non-residential buildings is also needed.

When structures are exposed to potentially damaging vibration, a description of the expected damage and the likelihood of such damage occurring should be provided for each type of structure. The information in Appendix C will be of some help in making this assessment, but often enough data will not be available to make a complete assessment. In such cases, a program for monitoring the actual damage, or lack of it, may be necessary.

REFERENCES

1. Council on Environmental Quality, National Environmental Policy Act-Regulations, Federal Register, Vol. 43, No. 112, June 9, 1978, pp. 25230-25247.
2. "Information on Levels of Environmental Noise Requisite To Protect Public Health and Welfare with an Adequate Margin of Safety," Report 550/9-74-004, U.S. Environmental Protection Agency, March 1974.
3. "Guidelines for Considering Noise in Land Use Planning and Control," Federal Interagency Committee on Urban Noise, June 1980.
4. "Sound Level Descriptors For Determination of Compatible Land Use," ANSI S3.23-1980, American National Standards Institute.
5. "Assessment of Community Response to High-Energy Impulsive Sounds," Report of Working Group 84, Committee on Hearing, Bioacoustics and Biomechanics, The National Research Council, Washington, D.C, 1981.
6. Schultz, T.J., "Synthesis of social surveys on noise annoyance, J. Acoust. Soc. Am., 64 (2), 1978, pp. 377-405.
7. "Public Health and Welfare Criteria for Noise," Report 550/9-73-002, U.S. Environmental Protection Agency, July 1973.
8. "Community Noise," Report NTID 300.3, U.S. Environmental Protection Agency, December 31, 1971.
9. "Code of Current Practices for Enforcement of Model Noise Control Ordinance," U.S. Environmental Protection Agency, September 1981.

10. Kurze, U.J., Levison, W.H., and Serben, S., "User's Manual for the Prediction of Road Traffic Noise Computer Programs," Report DOT-TSC-315-1, U.S. Department of Transportation, May 1972.
11. Gordon, C.G., Galloway, W.J., Kugler, B.A., and Nelson, D.L., "Highway Noise - A Design Guide for Engineers," Report 117, National Cooperative Highway Research Program, 1971.
12. Kugler, B.A., and Pierson, A.G., "Highway Noise - a Field Evaluation of Traffic Noise Reduction Measures," Report 144, National Cooperative Highway Research Program, 1973.
13. "Planning in the Noise Environment," Joint Services Manual AFM 19-10, TM 5-803-2, and NAVFAC P-970, June 1978.
14. "FFA Integrated Noise Model Version 1: User's Guide," Report FAA-EQ-78-01, Federal Aviation Administration, 1978.
15. "Calculation of Day-Night Levels (L_{dn}) Resulting from Civil Aircraft Operations," Report 550/9-77-450, U.S. Environmental Protection Agency, 1977.
16. Galloway, W.J., Eldred, K. McK., and Simpson, M.A., "Population Distribution of the United States as a Function of Outdoor Noise Level," Report 550-9-74-009, U.S. Environmental Protection Agency, June 1974.
17. Borsky, P.N., "The use of social surveys for measuring community responses to noise environments," in Transportation Noises, J.D. Chalupnik (ed). University of Washington Press, Seattle, 1970, pp. 219-227.

18. Schultz, T.J., "Social surveys on noise annoyance - further considerations." in Proceedings of the Third International Congress on Noise as a Public Health Problem, J.V. Tobias (ed). American Speech and Hearing Association, Washington, D.C., 1979.
19. von Gierke, H.G. (Task Group Chairman), "Impact Characterization of Noise Including Implications of Identifying and Achieving Levels of Cumulative Noise Exposure," Report NTID 73.4, U.S. Environmental Protection Agency, Aircraft/Airport Noise Study Report, July 1973.
20. "Noise-Final Report," H.M.S.O., Cmnd. 2056, London, July 1963.
21. Connor, W.K. and Patterson, H.P., "Community Reaction to Aircraft Noise Around Smaller City Airports," NASA CR-2104, August 1972.
22. "Social and Economic Impact of Aircraft Noise," Sector Group on the Urban Environment, OECD, April 1973.
23. Lukas, J.S., "Measures of Noise Level: Their Relative Accuracy in Predicting Objective and Subjective Responses to Noise during Sleep," Report 600/1-77-010. U.S. Environmental Protection Agency, February 1977.
24. Goldstein, J., "Assessing the impact of transportation noise: human response measures," in Proceedings of the 1977 National Conference on Noise Control Engineering, G.C. Maling (ed). Noise Control Foundation, Poughkeepsie, New York, 1977, pp. 79-98.
25. Goldstein, J. and Lukas, J.S., "Noise and Sleep: Information Needs for Noise Control," in Proceedings of the Third International Congress on Noise as a Public Health Problem, J.V. Tobias (ed). American Speech and Hearing Association, Washington, D.C., 1979.

26. "Noise Emission Standards for Surface Transportation Equipment: Regulatory Analysis of the Noise Emission Regulations for Truck-Mounted Solid Waste Compactors," Report 550/9-79-257, U.S. Environmental Protection Agency, August 1979.

27. Galloway, W.J., "Evaluating the Impact on the Public Health and Welfare of a Change in Environmental Noise Exposure," Appendix D of "Design Guide for Highway Noise Prediction and Control," Final Report Project 3-7/3, Submitted to Transportation Research Board, NCHRP, National Academy of Sciences, November 1974.

28. Baughn, W.L., "Relation Between Daily Noise Exposure and Hearing Loss Based on the Evaluation of 6,835 Industrial Noise Exposure Cases," Joint EPA/USAF Study, prepared for 6570th Aerospace Medical Research Laboratory, Wright-Patterson AFB, Ohio. AMRL-TR-73-53, 1973.

29. Passchier-Vermeer, W., "Hearing Loss Due to Exposure to Steady-State Broadband Noise." Instituut Voor Gezondheidstechniek, Sound and Light Division, Report 35, April 1968 (with supplement, 1969).

30. Robinson, D.W., "Estimating the risk of hearing loss due to exposure to continuous noise," Occupational Hearing Loss, British Acoustical Society Special Volume No. 1, London and New York, Academic Press, 1971, pp. 43-62.

31. Johnson, D.L. "Prediction of NIPTS Due to Continuous Noise Exposure" Report 550/9-73-001-B (or AMRL-TR-73-91), U.S. Environmental Protection Agency, 1973.

32. Harrison, R.T., Clark, R.N., and Stankey, G.H., "Predicting Impact of Noise on Recreationists," ED&T Project No. 2688, U.S. Department of Agriculture, Equipment Development Center, April 1980.
33. Borsky, P.N., "Community Reactions to Sonic Booms in the Oklahoma City Area," Report AMRL-TR-65-37, National Opinion Research Center, 1965.
34. Schomer, P.D., "Community Reaction to Impulse Noise: Initial Army Survey," Report, CERL-TR-N-100, U.S. Army Construction Engineering Research Laboratory, June 1981.
35. Schomer, P.D., "Evaluation of C-weighted L_{dn} for assessment of impulse noise," J. Acoust. Soc. Am., 62 (2), 1977, pp. 396-399.
36. Schomer, P.D., "Human and Community Response to Impulse Noise: A Literature Review," Illinois Institute for Environmental Quality, Document No. 78/07, March 1978.
37. Siskind, D.E., Stachura, V.J., Stagg, M.S., and Kopp, J.W., "Structure Response and Damage Produced by Airblast From Surface Mining," Report RI 8485, U.S. Department of the Interior, Bureau of Mines, 1980.
38. Johnson, D.R. and Robinson, D.W., "The subjective evaluation of sonic bangs," Acustica, 18, 1967, pp. 241-258.
39. Pawlowska, V. and Little, L., "The Blast Noise Prediction Program: User Reference Manual," Interim Report N-75, U.S. Army Construction Engineering Research Laboratory," August 1979.
40. Schomer, P.D., "Growth functions for human response to large-amplitude impulse noise," J. Acoust. Soc. Am., 64 (6), 1978, pp. 1627-1632.

41. Schomer, P.D., Goff, R.J., and Little, L.M., "The Statistics of Amplitude and Spectrum of Blasts Propagated in the Atmosphere," Vol. I., Report CERL-TR-N-13, U.S. Army Construction Engineering Research Laboratory, 1976.
42. "Airblast Characteristics for Single Point Explosions in Air, With Guide to Evaluation of Atmospheric Propagation and Effects," Draft ANSI 32.20-198X.
43. Johnson, L. "Auditory and physiological effects of infrasound," Inter-noise 75 Proceedings, Sendai, Japan, 1975, pp. 475-482.
44. von Gierke, H.E. and Parker, D.E., "Infrasound", in Handbook of Sensory Physiology, Vol. 5, Auditory System, Part 3, Springer-Verlag, Berlin-Heidelberg-New York, 1976, pp. 585-624.
45. "Guide for the Evaluation of Human Exposure to Whole-body Vibration," ISO 2631-1978, International Organization for Standardization, and Addendum 2, "Vibration and Shock Limits for Occupants in Buildings."
46. "Guide for the Evaluation of Human Exposure to Whole-body Vibration," ANSI S3.18-1979, American National Standards Institute.
47. "Guide for the Evaluation of Human Exposure to Vibration in Buildings," Proposed ANSI S3.29-198X, American National Standards Institute.
48. Nicholls, H.R., Johnson, C.F., and Duvall, W.I., "Blasting Vibrations and their Effects on Structures," Bulletin 656, U.S. Department of the Interior, Bureau of Mines, 1971.
49. Siskind, D.E., Stagg, M.S., Kopp, J.W., and Dowding, C.H., "Structure Response and Damage Produced by Ground Vibration From Surface Mine Blasting," Report RI 8507, U.S. Department of the Interior, Bureau of Mines, 1980.

50. "Guidelines for Preparing Environmental Impact Statements on Noise,"
Report of Working Group 69, Committee on Hearing, Bioacoustics and Bio-
mechanics, The National Research Council, Washington, D.C, 1977.

APPENDIX A

ACOUSTICAL TERMS AND SYMBOLS USED IN THE GUIDELINES, AND SOME MATHEMATICAL FORMULATIONS FOR THEM

A.1. Acoustical terms

Some acoustical terms are defined or described here, which have been used in the main body of this report. They are arranged alphabetically, to facilitate finding them as needed. Three key terms--sound level, equivalent sound level, and sound exposure level--receive non-technical as well as technical descriptions.

A.1.1 C-weighted sound exposure level. In decibels, the level of the time integral of C-weighted squared sound pressure, with reference to the square of 20 micropascals and to one second.

A.1.2 day-night sound level. The 24-hour equivalent sound level, in decibels, obtained after addition of 10 decibels to sound levels in the night from midnight up to 7 a.m. and from 10 p.m. to midnight (0000 up to 0700 and 2200 up to 2400 hours).

A.1.3 day-night sound level contour. A curved line connecting places on a map where the day-night sound level is the same. If only one kind of contour is shown on the map the fact may be made known by a single legend, "Contours of day-night sound level in decibels." In this case only the number of decibels need be marked on a contour.

A.1.4 day sound level. Equivalent sound level over the 15-hour time period from 7 a.m. up to 10 p.m. (0700 up to 2200 hours).

A.1.5 decibel. A unit measure of sound level and other kinds of levels. It is a logarithmic measure. For sound level specifically it is equal to $10 \log (p^2/p_{ref}^2)$ or $20 \log (p/p_{ref})$.

A.1.6 8-hour equivalent C-weighted sound level. Equivalent sound level, in decibels, over a given 8-hour time period, measured with the C-frequency weighting.

A.1.7 8-hour equivalent sound level. Equivalent sound level, in decibels, over an 8-hour period. The A-frequency weighting is understood.

A.1.8 equivalent sound level. A sound level typical of the sound levels at a certain place in stated time period. Technically, equivalent sound level in decibels is the level of the mean-square A-weighted sound pressure during the stated time period, with reference to the square of the standard reference sound pressure of 20 micropascals. Equivalent sound level differs from sound level in that for equivalent sound level, equal emphasis is given to all sounds within the stated averaging period, whereas for sound level an exponential time weighting puts much more emphasis on sounds that have just occurred than those which occurred earlier.

A.1.9 fast sound level. In decibels, the exponential-time-average sound level measured with the squared-pressure time constant of 125 ms.

A.1.10 hourly equivalent sound level. Equivalent sound level, in decibels, over a one-hour time period, usually reckoned between integral hours. It may be identified by the beginning and ending times, or by the ending time only.

A.1.11 impulse sound level. In decibels, the exponential-time-average sound level obtained with a squared-pressure time constant of 35 milliseconds.

A.1.12 instantaneous sound pressure, overpressure. Pressure at a place and instant considered, minus the static pressure there.

A.1.13 maximum sound pressure level. Same as peak sound pressure level, provided that the time interval considered is not less than a complete period of a periodic wave.

A.1.12 instantaneous sound pressure, overpressure. Pressure at a place and instant considered, minus the static pressure there.

A.1.13 maximum sound pressure level. Same as peak sound pressure level, provided that the time interval considered is not less than a complete period of a periodic wave.

A.1.14 night sound level. Equivalent sound level, in decibels, over the nine-hour period from midnight up to 7 a.m. and from 10 p.m. to midnight (0000 up to 0700 and 2200 up to 2400 hours).

A.1.15 noise level. Same as sound level, for sound in air. Some people use "noise" only for sound that is undesirable. A sound level meter does not, however, measure people's desires. Hence there is less likelihood of misunderstanding, if what is measured by a sound level meter is called sound level, rather than noise level.

A.1.16 peak sound pressure. Greatest absolute instantaneous sound pressure in a stated frequency band, during a given time interval. (Also called peak pressure.)

A.1.17 peak sound pressure level. In decibels, twenty times the common logarithm of the ratio of a greatest absolute instantaneous sound pressure to the reference sound pressure of twenty micropascals.

A.1.18 slow C-weighted sound level. In decibels, the exponential time average sound level measured with the squared-pressure time constant of one second and the C-frequency weighting of the sound level meter.

A.1.19 slow sound level. In decibels, the exponential-time-average sound level measured with the squared-pressure time constant of one second.

A.1.20 sound exposure. Time integral of squared, A-frequency-weighted sound pressure over a stated time interval or event. The exponent of sound pressure and the frequency weighting may be otherwise if clearly so specified.

A.1.21 sound exposure level. The level of sound accumulated over a given time period or event. It is particularly appropriate for a discrete event such as the passage of an airplane, a railroad train, or a truck. Sound exposure level is not an average, but a kind of sum. In contrast to equivalent sound level which may tend to stay relatively constant even though the sound fluctuates, sound exposure level increases continuously with the passing of time. Technically, sound exposure level in decibels is the level of the time integral of A-weighted squared sound pressure over a stated time interval or event, with reference to the square of the standard reference pressure of 20 micropascals and reference duration of one second.

A.1.22 sound level. The weighted sound pressure level, which reduces to a single number the full information about sound pressure levels across the frequency range 20 Hz to 20 kHz. It can be measured by a sound level

meter which meets the requirements of American National Standard Specification for Sound Level Meters S1.4-1971. In these guidelines, fast time-averaging and A-frequency weighting are understood, unless others are specified. The sound level meter with the A-weighting is progressively less sensitive to sounds of frequency below 1000 hertz (cycles per second), somewhat as is the ear. With fast time averaging the sound level meter responds particularly to recent sounds almost as quickly as does the ear in judging the loudness of a sound.

A.1.23 sound pressure. Root-mean-square of instantaneous sound pressures over a given time interval. The frequency bandwidth must be identified.

A.1.24 sound pressure level. In decibels, twenty times the common logarithm of the ratio of a sound pressure to the reference sound pressure of twenty micropascals (0.0002 microbar). The frequency bandwidth must be identified.

A.1.25 (vibratory) acceleration. The rate of change of velocity of a vibration, in a specified direction. The frequency bandwidth must be identified.

A.1.26 (vibratory) acceleration level. In decibels, twenty times the common logarithm of the ratio of a vibratory acceleration to the reference acceleration of ten micrometers per second squared (nearly one-millionth of the standard acceleration of free fall). The frequency bandwidth must be identified.

A.1.27 yearly day-night sound level. The day-night sound level, in decibels, averaged over an entire calendar year.

A.2. Symbols used in the guidelines

A.1.1	C-weighted sound exposure level	L _{SC}
A.1.2	day-night sound level	L _{dn}
A.1.5	decibel	dB
A.1.7	8-hour equivalent sound level	L _{eq(8)}
A.1.8	equivalent sound level	L _{eq}
A.1.10	hourly equivalent sound level	L _{eq(1)}
A.1.17	peak sound pressure level	L _{pk}
A.1.21	sound exposure level	L _S
A.1.23	sound pressure	p
A.1.25	vibratory acceleration	a
A.1.27	yearly day-night sound level	L _{dn(y)}

A.3. Mathematical formulations for the descriptors used in the guidelines

A.3.1 Equivalent sound level

$$L_{eq} = 10 \log_{10} \left[\frac{1}{T} \int_0^T 10^{L_A(t)/10} dt \right] \quad \text{Eqn A-1}$$

where: T is the length of the time interval during which the average is taken, and L_A(t) is the time varying value of the A-weighted sound level during the time interval T.

Note: Equivalent sound level may be calculated from the sound exposure levels of individual events occurring within the time interval T:

$$L_{eq} = 10 \log_{10} \left[\frac{1}{T} \sum_{i=1}^n 10^{L_{Si}/10} \right] \quad \text{Eqn A-2}$$

where: L_{Si} is the sound exposure level of the i -th event, out of a total of n events in time interval T . L_S is defined in A.2.3.4.

A.3.2 Day-night Sound Level

$$L_{dn} = 10 \log_{10} \left[\frac{1}{86400} \left(\int_{0000}^{0700} 10^{[L_A(t)+10]/10} dt + \int_{0700}^{2200} 10^{L_A(t)/10} dt + \int_{2200}^{2400} 10^{[L_A(t)+10]/10} dt \right) \right]$$

Eqn A-3

Time t is in seconds, so the limits shown in hours and minutes are actually interpreted in seconds. It is often convenient to compute day-night sound level from hourly equivalent sound levels obtained during successive hours:

$$L_{dn} = \log_{10} \left[\frac{1}{24} \left(\sum_{i=1}^{15} 10^{L_{di}/10} + 10 \sum_{j=1}^9 10^{L_{nj}/10} \right) \right]$$

Eqn A-4

where L_{di} is the hourly equivalent sound level for the i -th hour of the day and L_{nj} is the hourly equivalent sound level for the j -th hour of the night.

A.3.3 Yearly Day-night Sound Level

$$L_{dn}(y) = 10 \log_{10} \frac{1}{365} \sum_{i=1}^{365} 10^{L_{dni}/10}$$

Eqn A-5

where: L_{dni} is the day-night average sound level for the i -th day out of one year.

A.3.4 Sound Exposure Level

$$L_S = 10 \log_{10} \left(\int_{t_1}^{t_2} 10^{L_A(t)/10} dt \right) \quad \text{Eqn A-6}$$

where: $L_A(t)$ is the time-varying A-weighted sound level in some time interval t_1 to t_2 .

The length of the time interval may be arbitrary, or it may simply be large enough to encompass all the significant sound of an event.

Note: The value of the above integral is usually approximated with sufficient accuracy by integrating $L_A(t)$ over the time interval during which $L_A(t)$ is between 10 decibels less than its maximum value and the maximum value, before and after the maximum occurs.

A.3.5 C-weighted Sound Exposure Level

$$L_{SC} = 10 \log_{10} \left(\int_{t_1}^{t_2} 10^{L_C(t)/10} dt \right) \quad \text{Eqn A-7}$$

where: $L_C(t)$ is the time-varying C-weighted sound level in some time interval t_1 to t_2 .

Note: In practice the integral is often approximated by integration within the time during which the sound level of the event exceeds some threshold value such as 20 dB less than the maximum sound pressure level.

A.3.6 C-weighted Day Night Sound Level

Analogous to the A-weighted L_{dn} , with a nighttime penalty of 10 dB, the C-weighted day-night average sound level is:

$$L_{Cdn} = 10 \log_{10} \frac{1}{24} \left[15 \times 10^{\frac{L_{Cd}}{10}} + 9 \times 10^{\frac{L_{Cn} + 10}{10}} \right] \quad \text{Eqn A-8}$$

L_{Cd} is the average C-weighted sound level over the daytime period of 0700 to 2200 hours, L_{Cn} is the C-weighted average level over the nighttime period of 2200 to 0700 hours.

The C-weighted average level is most easily calculated from the C-weighted sound exposure levels during the time of interest as follows:

$$L_{Cd} = 10 \log \frac{1}{15 \times 3600} \left[\sum_i^n 10^{\frac{L_{SCi}}{10}} \right] \quad \text{for } L_{SCi} > 80 \quad \text{Eqn A-9}$$

$$L_{Cn} = 10 \log \frac{1}{9 \times 3600} \left[\sum_i^n 10^{\frac{L_{SCi}}{10}} \right] \quad \text{for } L_{SCi} > 70 \quad \text{Eqn A-10}$$

where L_{SC} is the C-weighted sound exposure level of the i -th discrete event.

APPENDIX B
ENVIRONMENTAL NOISE MEASURES AND
PROCEDURES

B1. ENVIRONMENTAL NOISE MEASURES AND THEIR PURPOSES IN FEDERAL PROGRAMS

AGENCY	1. FEDERAL INTERAGENCY COMMITTEE ON URBAN NOISE (DOT, DOD, EPA, VA, HUD)	2. FHWA	3. EPA	4. HUD	5. DOD	6. FAA	7. VA
Type of Program or Policy	Uniform Federal position on noise and land use planning for state and local governments and others.	Highway Noise Policy	Health & Welfare Guidance	HUD Noise Regulations	Airport Installation Compatible Use Zones (AICUZ) Program	Airport Noise Compatibility Planning	VA Noise Policy
Key Documents	Guidelines for Considering Noise in Land Use Planning and Control (1970) NTIS: PB 81-214-124	FHPM 7-7-3 (May 1976) (Latest revision, May 1979)	EPA "Levels" Document (1974)	24 CFR Part 61 Subpart B; Noise Assessment Guidelines (1980)	DOD Instruction 4185 57 (1977)	Aviation Safety and Noise Abatement Act of 1979 (ASNA), Federal Aviation Regulation, Part 150.	Section VIII Appraisal of residential properties near Airports (1969)
Title of Levels	Land Use Compatibility Guidelines	Design Noise Levels	Levels which are required to protect the public health and welfare with an adequate margin of safety.	Levels which determine whether proposed sites are eligible for HUD insurance or assistance.	Levels used as "reasonable" guidance to communities for planning	Land uses that are normally compatible or non-compatible with various levels of noise exposure by individuals.	Levels determining whether projected sites are eligible for VA assistance.
Purpose of Levels	Provides land use planning guidance to communities and states. Guidelines set forth linkages between various noise levels and compatible land use. Guidelines balance effects of noise on the community against local developmental needs, costs, and feasibility, facilitating local decisions as to compatibility of specific developmental projects with specific local noise conditions.	These levels are used in determining where noise mitigation on a particular highway project is warranted. They reflect cost and feasibility considerations. They are not separate land use criteria. Design noise levels depend upon land use activity.	These levels identify in scientific terms the threshold of effect. While the levels have relevance for planning, they do not in themselves form the sole basis for appropriate land use actions because they do not consider cost, feasibility or the development needs of the community. The user should make such tradeoffs.	See above. Levels can be used as general planning levels. Reflect cost, feasibility, general program objectives and consideration of health and welfare goals.	Guidance to communities for planning. Considers balance between cost, feasibility, effect, community development needs and availability of land for development. Community wide consideration.	Guidance for determining compatible or non-compatible land uses for airport noise exposure maps and airport noise compatibility programs submitted to the FAA under Title I of the ASNA Act for formal approval.	Establishes noise limits beyond which VA will not accept residential construction. While the levels have relevance for planning, they do not in themselves form the sole basis for appropriate land use actions because they do not consider cost, feasibility or the development needs of the community. The user should make such tradeoffs.
Source to which applied	All sources	Highway only	All sources	All sources	Military Airfields	Civil Airports	Airports only
Noise Descriptors Used	L_{dn}	L_{eq} or L_{10} for design hour	L_{dn}	Various (accepts L_{dn})	L_{dn}	L_{dn}	Various (including L_{dn})

B.2. Estimating L_{dn} from other Noise Measures

The equations listed here are approximations only, and are provided for use in those situations in which measurement or prediction of the other noise measure is already available. If no such information is available, it is strongly recommended that L_{dn} be measured or predicted directly, instead of using these equations.

NEF:	$L_{dn} \approx NEF + 35$	Eqn B-1
CNR:	$L_{dn} \approx CNR - 35$	Eqn B-2
CNEL:	$L_{dn} \approx CNEL$	Eqn B-3
24-hour L_{eq} : ^a	$L_{dn} \approx L_{eq}(24) + 4$	Eqn B-4
Peak (traffic) hour L_{eq} : ^b	$L_{dn} \approx L_{eq}(1)$	Eqn B-5
Peak (traffic) hour L_{10} : ^b	$L_{dn} \approx L_{10} - 3$	Eqn B-6

Notes:

^a Source: [19], Parts II B, F, and Addendum A, approximated.

^b Source: Department of Housing and Urban Development. Notice of proposed rulemaking, Environmental criteria and standards, Federal Register, Vol 43, No. 249, December 29, 1978, p. 60399. "The day-night average sound level may be estimated from the design hour L_{10} or L_{eq} values by [these] relationships, provided heavy trucks do not exceed 10 percent of the total traffic flow in vehicles per 24 hours and the traffic flow between 10 p.m. and 7 a.m. does not exceed 15 percent of the average daily traffic flow in vehicles per 24 hours."

APPENDIX C

SUMMARY OF HUMAN EFFECTS OF GENERAL AUDIBLE NOISE

TABLE C1 Summary of Human Effects for Outdoor Day-Night Sound Level of 75 Decibels

<u>Type of Effect</u>	<u>Magnitude of Effect</u>
Hearing Loss	May begin to occur in sensitive individuals, depending on actual noise levels received at-ear.
Risk of non-auditory health effects (stress) *	
Speech [*] - Indoors	Some disturbance of normal conversation. Sentence intelligibility (average) approximately 98%
- Outdoors	Very significant disturbance of normal voice or relaxed conversation with: 100% sentence intelligibility not possible at any distance or, 99% sentence intelligibility (average) at 0.15 meter or, 95% sentence intelligibility (average) at 0.5 meter
High Annoyance	Depending on attitude and other non-acoustical factors, approximately 37% of the population will be highly annoyed.
Average Community Reaction	Very severe; 13 dB above level of significant "complaints and threats of legal action" and at least 3 dB above "vigorous action" (attitudes and other non-acoustical factors may modify this effect).
Attitudes Towards Area	Noise is likely to be the most important of all adverse aspects of the community environment.

*Research implicates noise as one of several factors producing stress-related health effects such as heart disease, high-blood pressure and stroke, ulcers and other digestive disorders. The relationships between noise and these effects have not yet been quantified, however.

^{*}The speech effects data in these tables are drawn from the Levels Document, as follows. Indoor effects are based on Table 3, and on Fig. D-1, with 15 dB added to the indoor level to obtain the outdoor reading. Outdoor effects come from Fig. D-2, using L_d (as determined with Fig. A-7). Both Figures D-1 and D-2 are based on steady noise, not on L_{eq} . Table D-3 shows that for a fluctuating noise, the average percent interference can be higher or lower than for steady noise with the same L_{eq} . The values given in this report are the best estimates of the interference.

TABLE C2 Summary of Human Effects for Outdoor Day-Night Sound Level of 70 Decibels

<u>Type of Effect</u>	<u>Magnitude of Effect</u>
Hearing Loss	Will not likely occur
Risk of non-auditory health effects (stress)	See Table C1
Speech - Indoors	Slight disturbance of normal conversation approximately 99% sentence intelligibility (average)
- Outdoors	Significant disturbance of normal voice or relaxed conversation with 100% sentence intelligibility (average) possible only at distances less than 0.1 meter
	or
	99% sentence intelligibility (average) at 0.3 meter
	or
	95% sentence intelligibility (average) at 0.9 meter
High Annoyance	Depending on attitude and other non-acoustical factors, approximately 25 percent of the population will be highly annoyed.
Average Community Reaction	Severe; 8 dB above level of significant "complaints and threats of legal action," but at least 2 dB below "vigorous action" (attitudes and other non-acoustical factors may modify this effect)
Attitudes Towards Area	Noise is one of the most important adverse aspects of the community environment

TABLE C3 Summary of Human Effects for Outdoor Day-Night Sound Level of 65 Decibels

<u>Type of Effect</u>	<u>Magnitude of Effect</u>
Hearing Loss	Will not occur
Risk of non-auditory health effects (stress)	See Table C1
Speech - Indoors	Slight disturbance of normal conversation 99% sentence intelligibility (average) with a 4 dB margin of safety
- Outdoors	Significant disturbance of normal voice or relaxed conversation with 100% sentence intelligibility (average) at 0.15 meter or 99% sentence intelligibility (average) at 0.5 meter or 95% sentence intelligibility (average) at 1.5 meters
High Annoyance	Depending on attitude and other non-acoustical factors, approximately 15 percent of the population will be highly annoyed.
Average Community Reaction	Significant; 3 dB above level of significant "complaints and threats of legal action," but at least 7 dB below "vigorous action" (attitudes and other non-acoustical factors may modify this effect)
Attitudes Towards Area	Noise is one of the important adverse aspects of the community environment

TABLE C4 Summary of Human Effects for Outdoor Day-Night Sound Level of 60 Decibels

<u>Type of Effect</u>	<u>Magnitude of Effect</u>
Hearing Loss	Will not occur
Risk of non-auditory health effects (stress)	See Table C1
Speech - Indoors	No disturbance of normal conversation 100% sentence intelligibility (average) with no margin of safety
- Outdoors	Moderate disturbance of normal voice or relaxed conversation with 100% sentence intelligibility (average) at 0.2 meter or 99% sentence intelligibility (average) at 0.6 meter or 95% sentence intelligibility (average) at 2 meters
High Annoyance	Depending on attitude and other non- acoustical factors, approximately 9 percent of the population will be highly annoyed.
Average Community Reaction	Slight to moderate; 2 dB below level of significant "complaints and threats of legal action," but at least 11 dB below "vigorous action" (attitudes and other non-acoustical factors may modify this effect)
Attitudes Towards Area	Noise may be considered an adverse aspect of the community environment

TABLE C5 Summary of Human Effects for Outdoor Day-Night Sound Level of 55 Decibels

<u>Type of Effect</u>	<u>Magnitude of Effect</u>
Hearing Loss	Will not occur
Risk of non-auditory health effects (stress)	See Table C1
Speech - Indoors	No disturbance of normal conversation 100% sentence intelligibility (average) with a 5 dB margin of safety
- Outdoors	Slight disturbance of normal voice or relaxed conversation with: 100% sentence intelligibility (average) at 0.35 meter or 99% sentence intelligibility (average) at 1.0 meter or 95% sentence intelligibility (average) at 3.5 meters
High Annoyance	Depending on attitude and other non- acoustical factors, approximately 4 percent of the population will be highly annoyed.
Average Community Reaction	None expected; 7 dB below level of signi- ficant "complaints and threats of legal action," but at least 16 dB below "vigorous action" (attitudes and other non-acoustical factors may modify this effect)
Attitudes Towards Area	Noise considered no more important than various other environmental factors

APPENDIX D

MEASUREMENT OF AND CRITERIA FOR HUMAN VIBRATION EXPOSURE

D.1. Introduction

The criteria for vibration exposure in this appendix will address 3 types of effects. These three types of effects are: (1) whole body vibration of humans, (2) annoyance and interference caused by building vibration, and (3) structural damage from building vibration.

The existing state of knowledge is not complete in any of the above three areas; however, there are existing I.S.O. standards that have been approved or proposed. Summaries of these standards, along with other data, provide the content of this appendix. Some simplification of the proposed standards on building vibration and structural damage have been made in order to provide a simple, unified and reasonable method for assessing the effects of vibration.

D.2. Whole body vibration criteria (Summary of Approved ISO Standard 2631-1978)

D.2.1 The three criteria for evaluation of whole body vibration

Experimental data show that there are various rather complex factors that determine the human response to vibration. Evaluation of all these factors is difficult at this time because of the paucity of quantitative data concerning man's perception of vibration and his response to it. Nevertheless, there is an international standard which does provide provisional guidance as to what is acceptable human exposure to vibration for some types of vibration.

In general, there are four physical factors of primary importance in determining the human response to vibration. These are intensity, frequency,

direction, and exposure time of the vibration. The current International Standard for vibration addresses three main human criteria. These are:

1. Preservation of working efficiency
2. Preservation of health or safety
3. The preservation of comfort

For environmental problems, the preservation of comfort is considered the best criteria for evaluation of whether or not vibration significantly changes the environment.

D.2.2 Types of vibration transmissions

The standard lists basically three kinds of human response to vibration, namely:

(a) Vibrations transmitted simultaneously to the whole body surface or substantial parts of it. This occurs when the body is immersed in a vibration medium. There are circumstances in which this is of practical concern; for example, when high intensity sound in air or water excites vibrations of the body.

(b) Vibration transmitted to the body as a whole through the supporting surface, namely, the feet of a standing man, the buttocks of a seated man or the supporting area of a reclining man. This kind of vibration is usual in vehicles, in vibrating buildings and in the vicinity of working machinery.

(c) Vibrations applied to particular parts of the body such as the head or limbs; for example, by vibrating handles, pedals, or head-rests, or by the wide variety of powered tools and appliances held in the hand.

It is also possible to recognize the condition in which an indirect vibration nuisance is caused by the vibration of external objects in the visual field (for example, an instrument panel).

The International Standard 2631, however, applies chiefly to the common condition (b) above; and, in particular, where the vibration is applied through the principal supporting surface to the body of a standing or seated man. In the case of vibrations applied directly to a reclining or recumbent man, insufficient data are available to make a firm recommendation; this is particularly true of vibration transmitted directly to the head, when tolerability is generally reduced. Tolerance may also be reduced when conditions (b) and (c) exist together. Provisionally, however, the limits for the standing or seated man may also be used for the reclining or recumbent man. It must be appreciated that some circumstances will arise in which the rigorous application of these limits would be inappropriate.

D.2.3 Direction of vibration

Rectilinear vibrations transmitted to man should be measured in the appropriate directions of an orthogonal coordinate system centered at the heart. The standard specifies separate criteria according to whether the vibration is in the longitudinal ($\pm a_z$) direction or transverse ($\pm a_x$ or a_y) plane. Accelerations in the foot (or buttocks) - to head (or longitudinal) axis are designated $\pm a_z$; acceleration in the fore-and-aft (anterior-posterior or chest-to-back) axis, $\pm a_x$; and in the lateral (right-to-left side) axis, $\pm a_y$. These axes are illustrated in Figure D-1.

D.2.4 Acceptable whole body vibration

The ISO standard identifies the 24-hr comfort level for rms pure (sinusoidal single) frequency or rms value in third octave band for random vibration as given in Table D-1. As long as the vibration levels are below the 24-hr levels, vibration should be considered to have no direct impact on an individual, regardless of the duration of the exposure. The standard does

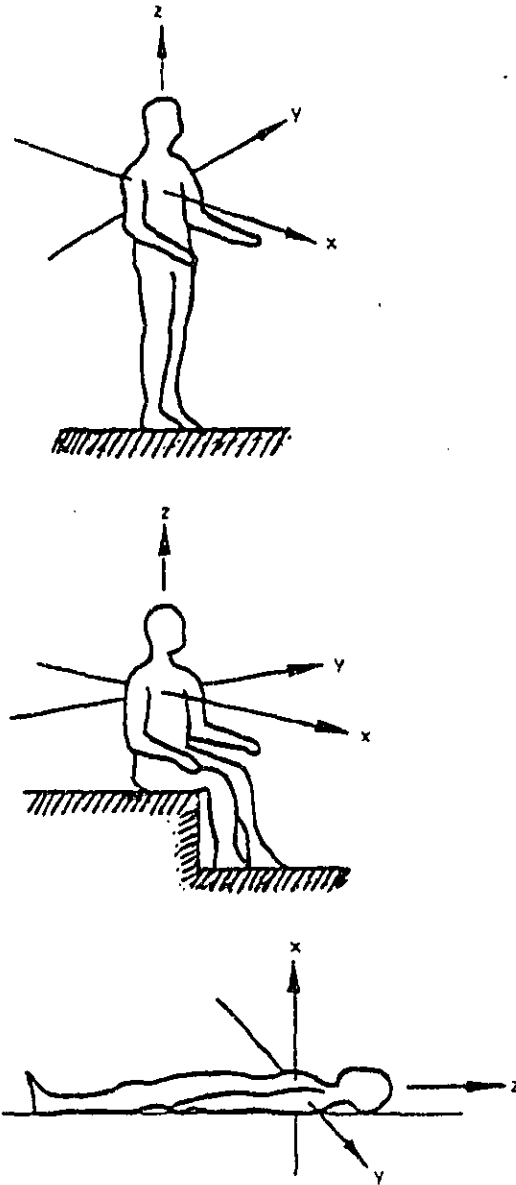

a_x, a_y, a_z = acceleration in the directions of the x, y, z axes
 x axis = back to chest
 y axis = right to left side
 z axis = foot for buttock (s)-to-head

FIGURE D-1. Directions of co-ordinate system for mechanical vibrations influencing humans

TABLE D-1 - Numerical values of "comfort boundary" for vibration acceleration in the longitudinal, a_z , direction (foot (or buttocks)-to-head direction) (see Figure D-1 and in the transverse, a_x or a_y , direction (back-to-chest or side-to-side)
 Values define the boundary in terms of rms value of pure (sinusoidal) single frequency vibration; or rms value in third-octave band for distributed vibration.

Frequency (Hz) (Center Frequency of 1/3 Octave Band)	ACCELERATION m/sec					
	a_z			a_x or a_y		
	1 min	8 hr	24 hr	1 min	8 hr	24 hr
1	1.78	0.2	0.07	0.63	0.07	0.03
1.25	1.59	0.18	0.06	0.63	0.07	0.03
1.6	1.43	0.16	0.06	0.63	0.07	0.03
2.0	1.27	0.14	0.05	0.63	0.07	0.03
2.5	1.13	0.13	0.04	0.79	0.09	0.04
3.15	1.00	0.11	0.04	1.0	0.11	0.05
4.0	0.89	0.1	0.04	1.27	0.14	0.06
5.0	0.89	0.1	0.04	1.59	0.18	0.08
6.3	0.89	0.1	0.04	2.00	0.24	0.10
8.0	0.89	0.1	0.04	2.54	0.29	0.13
10.0	1.13	0.13	0.04	3.17	0.36	0.16
12.5	1.43	0.16	0.06	3.97	0.44	0.20
16.0	1.78	0.2	0.07	5.08	0.57	0.25
20.0	2.25	0.25	0.09	6.35	0.71	0.32
25.0	2.86	0.32	0.11	7.94	0.89	0.40
31.5	3.56	0.40	0.14	10.00	1.13	0.51
40.0	4.44	0.51	0.18	12.70	1.43	0.63
50.0	5.71	0.63	0.23	15.87	1.78	0.79
63.0	7.11	0.79	0.29	20.00	2.25	1.00
80.0	8.89	1.0	0.36	25.40	2.86	1.27

allow for increased exposure levels for shorter exposure times. Such a trade-off is given by Table D-1 for 8-hr and 1 min exposures. For other exposure times and for the concept of a vibration dose, the basic standard should be consulted. For occupational and recreational situations, the values of Table D-1 can be raised by a factor of 3.15 (10 dB) to predict the boundary at which working efficiency may start to decrease. Increasing the acceleration listed in Table D-1 by a factor of 6.3 (16 dB) will give the boundary necessary for the preservation of health and safety. Thus the 1 min values of Table D-1 as multiplied by a factor of 6.3 provides the maximum recommended continuous acceleration to which an individual should be subjected. However, assessment of acceleration above the comfort levels listed in Table D-1 should be made only by direct reference to the ISO standard. In the ISO standard there are many considerations and limitations with respect to human exposure to acceleration that can cause reduced efficiency or health and safety problems.

D.3. Vibration criteria for occupants in buildings. (Summary of 1980 draft addendum 1 to ISO Standard 2631-1978, and modifications as contained in ANSI S3.29, Draft Standard Guide to the Evaluation of Human Exposure to Vibrations in Buildings.)

D.3.1 Scope

The proposed standard takes into account the following factors:

1. Type of Excitation - for example transient (shock) and/or steady vibration;
2. Usage of the Occupied Space in Buildings - for example, hospital operating theatres, residential, offices and factories;
3. Time of Day;

4. Limits of Acceptability - in a proposal of this type there is no hard and fast line of acceptability, but guidance is given as to the level of complaint to be achieved at different levels of vibration. In cases where sensitive equipment or delicate operations impose more stringent limits than human comfort criteria, then the more stringent criteria should be applied.

D.3.2 Characteristics of building vibration

D.3.2.1 Direction of vibration

Because a building may be used for many different activities, standing, sitting and lying may all occur, and hence, vertical vibration of the building may enter the body as either Z axis, X axis or Y axis vibration, as shown in Figure D-1. The Standard is written for all three axes of vibration. However, in cases where it is not clear which direction to apply, it is often more convenient to consider the combined Standard detailed in Sections D.3.3.4 below.

D.3.2.2 Random or multi-frequency vibration

Random or multi-frequency vibration represents a particular problem which fortunately does not often occur in buildings. There is evidence from research concerning the building environment to suggest that there are interaction effects between different frequencies of vibration. Under these circumstances and for random vibration, the proposed standard recommends an overall weighting method such as that in section D.3.3.4.

D.3.2.3 The characterization of impulsive shock and intermittent vibration

Continuous vibration of a repetitive nature is easy to identify and classify. The borderline between impulsive shock and intermittent vibration

is difficult to define. Impulsive shock is characterized by a rapid build-up to a peak followed by decay, and is typically excited in buildings by blasting, forging presses or pile driving using an impact device. Intermittent vibration may only last a few seconds, but is characterized by a build-up to a level which is maintained for a considerable number of cycles. Examples of this in buildings would be traffic excited vibration and vibration generated inside a building by machinery starting up or on intermittent service. Pile driving by modern methods using vibrating columns would also be classified as continuous or intermittent vibration and not as impulsive shock.

The proposed standard recommends that impulsive shock created by forging presses or conventional pile drivers should be treated in a similar manner to continuous and intermittent vibration. Research has shown that vibration which only occurs at a specific instance, for example domestic building vibration by a passing bus, causes the same level of annoyance as continuous vibration.

Blasting which occurs only up to three times per day is a special case. The proposed standard recommends that building operations of this nature should never take place at night due to the disturbance and that during the daytime they should be limited to a small number of occurrences. The levels of vibration generated due to blasting are on an order of magnitude greater than traffic and general building vibrations, and can only be accepted on the basis of very limited exposure.

D.3.2.4 Classification of buildings and building areas

The criteria of classification in the standard are derived from expectations of human reaction to vibration. In the home the highest standards are required, and this is characterized by an absence of detectable vibration.

Under other conditions, such as offices and factories, there is some tolerance to vibration disturbance.

In the proposed Standard no differentiation has been made between different types of residential areas, i.e. city centre, urban or rural. It is considered that similar standards should be met for all occupants of residential property. Some types of areas have not been classified, i.e. restaurants or places of entertainment, but common sense suggests the most appropriate classification--for example standards in a restaurant should be similar to those in residential property. It should be noted that certain entertainment areas in long span buildings present particular problems from self-generated vibration, such as that from dancing.

Hospitals have not been given more restrictive levels in general because there is some evidence that patients prefer to be in touch to some extent with the outside world, but operating theatres and laboratories should be considered as critical areas.

D.3.2.5 Measurement of vibration

The use of "root mean square" acceleration is recommended as the standard unit of measurement. If possible building vibration should be measured in acceleration terms, but in some cases it may be found necessary to measure in velocity or displacement due to equipment limitations. For these situations the vibration should be treated as sinusoidal and the appropriate correction factors, which are a function of frequency, used to transform either the measurement or the standard into compatible units.

In the case of impulsive vibration or shock the instantaneous peak value of velocity or acceleration is the preferred unit of measurement. A trace of the vibration should be obtained upon a suitable instrument and the peak level

estimated. The motion should then be considered sinusoidal and the correction factors applied for the difference between peak and rms, and the frequency dependent factors used to transform either measurement or standard into compatible units.

If frequency analysis of the vibration is required, third octave filters are recommended. In certain circumstances it may be useful to analyze the vibration in terms of narrow fixed band width filters.

Measurement of vibration should be taken on the floor at the point of greatest amplitude, commonly found at mid-span. This should be close to the point of entry of vibration to the human subject. Measurement should be taken along the three orthogonal axes, and reference made to the appropriate human axis standard to determine whether limits have been exceeded. Alternatively the weighting network or combination curves (see Section D.3.3.4) could be considered in relation to the worse case found.

In the case of impulsive shock caused by blasting, measurement may be made at the foundations to check for structural damage. It is also necessary to measure according to the technique given above in the areas of human habitation.

D.3.3 Characterization of building vibration and acceptable limits

D.3.3.1 Acceptable limits

All the following proposals are related to the recommendations for general vibration on humans given in Section D.2. The presentation of information is in the form of a basic rating which is given for the most stringent conditions. From this basic rating a multiplication factor is then applied according to the tables for other more permissive situations.

The lowest basic rating has been defined in the area of the threshold of human perception. It is based upon research work completed up to the end of 1975.

Experience has shown in many countries that complaints of building vibrations in residential situations are likely to arise from occupants if the vibration levels are only slightly in excess of perception levels. In general, the limits are related to the acceptance by the occupants and are not determined by any other factors such as short-term health and work efficiency. Indeed the levels are such that there is no possibility of fatigue or other vibration induced syndromes.

D.3.3.2 Head to foot ("Z" Axis) vibration limits

For Z axis the recommended vibration values proposed by the standard is shown in Figure D-2. For frequencies between 4 Hz and 8 Hz the maximum acceleration (rms) is $5 \times 10^{-3} \text{ m/s}^2$. At frequencies below 4 Hz the limit changes at 3 dB/octave. For frequencies greater than 8 Hz the limit increases by 6 dB/octave. For conditions other than the base curve a series of weighting factors apply and these are given in Table D-2. For example, for residential property the weighting factor is two, hence at 4 to 8 Hz the maximum recommended rms acceleration for residential property by day would be 10^{-2} m/s^2 .

D.3.3.3 Side to side or front to back (X or Y axis) vibration limits

For X and Y axis human vibration a different base curve applies which is shown in Figure D-2. For frequencies from 1 - 2 Hz a maximum acceleration level of $3.6 \times 10^{-3} \text{ m/s}^2$ will apply. At frequencies higher than 2 Hz the acceptable acceleration level will increase at 6 dB/octave. This means that for frequencies greater than 2 Hz a maximum rms velocity limit applies.

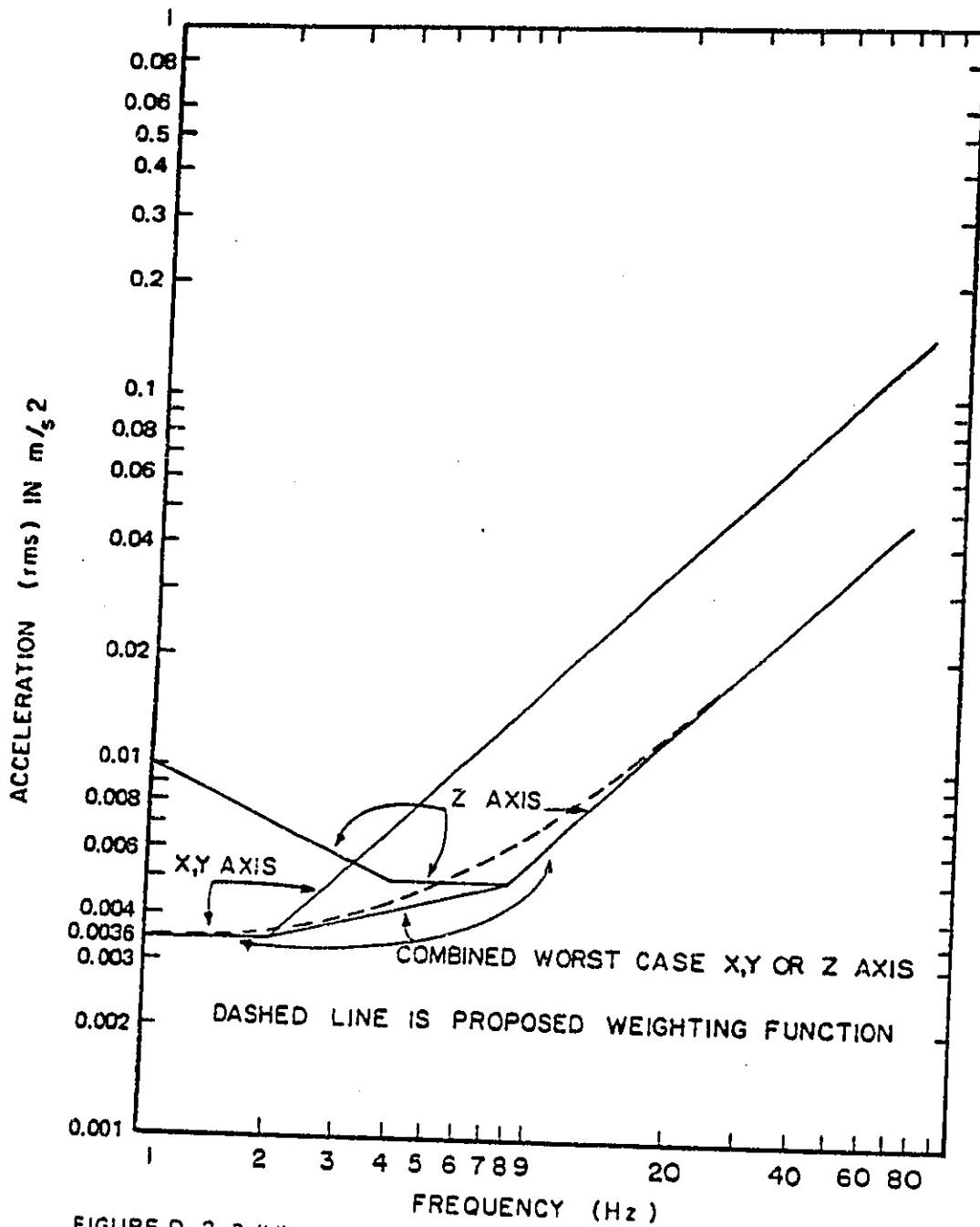

FIGURE D-2. Building vibration criteria for occupants in buildings. All curves are for hospital and critical working areas. See Table D-2 for proper scale factors.

TABLE D-2 WEIGHTING FACTORS FOR ACCEPTABLE BUILDING VIBRATION

Place	Time	Continuous or Intermittent Vibration & Repeated Impulsive Shock	Impulsive Shock Excitation with not more than 3 Occurrences per day
Hospital operating theatre & critical working areas	Day	1	1
	Night	1	1
Residential (minimum complaint level)	Day	2	90*
	Night	1.41	1.41
	Day	4	128
Office	Day	4	128
	Night	4	128
Workshop	Day	8	128
	Night	8	128

Weighting Factors above basic level of Curve shown in Figure D-2

 *Modified per proposed ANSI S3.29-198X, Draft ANSI Standard Guide to the Evaluation of Human Exposure to Vibration in Buildings.

It will be noted that the standard for X or Y axis vibration is more severe than the Z axis case at low frequencies. This is due to the sensitivity of the human body towards sway at these low frequencies.

The table of weighting factors given in Table D-2 also applies to X or Y axis vibration.

D.3.3.4 Combined standard - recommended limits for undefined axis of human vibration exposure

D.3.3.4.1 Worst case combination curve

In many situations the same building area may be used in both the lying and standing positions at different times of the day. If this is the case, then a combined Standard using the worst case combination of both the Z axis and X and Y axis conditions may be applied. This combination curve is shown in Figure D-2 and the same weighting factors given in Table D-2 still apply.

D.3.3.4.2 Proposed weighting network

The proposed standard also recommends a weighting network that closely approximates the combination curve. For routine measurement and evaluation of environmental vibration, this frequency weighting is recommended. The weighting function proposed for combined or random vibrations is given by:

$$G(J\omega) = \frac{1}{1 + \frac{J\omega}{11.2}}$$

Eqn D-1

where $G(J\omega)$ is the transmissibility of the filter, J represents the square root of -1 , ω represents the exciting frequency.

This mathematical expression defines the electronic weighting filter of the low pass type. At low frequencies the transmissibility is zero, and at

high frequencies attenuation is at 6 dB/octave. The corner frequency is 5.6 Hz. Accuracy - \pm 0.2 dB

Although the proposed standard recommends this function for preliminary investigations, for practical evaluations of the overall environmental impact of vibration on a community, the weighting function is a necessary and useful simplification, especially with respect to residential areas, that is not expected to introduce any significant errors.

D.4. Structural damage from building vibration. (Summary of 1976 draft Standard ISO/TC 108/SC 2/WG3

D.4.1 General considerations

The proposed standard discusses the following general considerations: Vibration in buildings (dwellings, offices, public buildings and factories) is of increasing general importance, especially since the distances between industrial areas with vibration exciting machines, blasts or other vibration sources and residential areas are decreasing. Traffic on roads and railroads also causes vibration troubles in nearby buildings.

Various methods of rating the severity of vibration in buildings and defining limits based on laboratory or field data have been developed in the past. However, none of these methods can be considered applicable in all situations and consequently none have been universally accepted.

In view of the complex factors required to determine the response of a building due to vibrations and in view of the paucity of quantitative data, this proposed Standard was prepared, first to facilitate the evaluation and comparison of data gained from continuing research in this field; and, second, to give provisional guidance as to the acceptable values in order to avoid the

risk of damage. The limits proposed are a compromise of available data. They satisfy the need for recommendations which are simple and suitable for general application. These limits are defined explicitly in numerical terms to avoid ambiguity and to encourage precise measurement in practice.

If the characteristics of the excitation vibration are known in relation to the severity, position and direction of the building response--this may be the case if the source of the vibration is within the building--and if the parts of the buildings or the whole building influenced by the vibrations can be idealized by a model, then it may be possible to estimate the severity of the dynamic stresses by calculation.

If vibrations are transmitted via the ground and the foundation into a building, it may be possible to estimate dynamic stresses based on vibration measurements.

In addition to simple vibration there may be other factors which influence vibration response (foundation conditions, dilatation due to temperature etc.) and which result in damage to buildings. No general method exists at present to take account into all such factors.

D.4.2 Categories of damage

The proposed standard provides several phases of damage which can occur, namely:

Category 1:

Threshold damage consists of visible cracks in non-structural members such as partitions, facings, plasterwalls (e.g. loosening of mortar between pan-tiles etc.). As a guideline visible cracks may be taken as those of a width of 0.02 mm.

RESTRICTION AREA

Category 2:

Minor damage consists of visible cracks in structural members such as masonry walls, beams, columns, slabs and no serious reduction in load carrying capacity.

Category 3:

Major damage consists of large permanent cracks in non-structural and structural members; settlement and displacements of foundations which may result in reduction of load carrying capacity.

The proposed standard applies chiefly to damage as described in categories 1 and 2. The limits of vibration specified in the standard were selected to avoid the exceeding of the threshold of damage, but does include data for estimating damage levels.

D.4.3 Measurement

D.4.3.1 Frequencies

The proposed standard recommends the following frequency ranges:

1. In the case of vibration caused by shock and quarry blasting and the steady vibration of whole buildings: from about 1 Hz to about 100 Hz.
2. In the case of steady vibration of parts of a building, especially floor and wall vibrations: from about 10 Hz to about 100 Hz.

D.4.3.2 Measurement points

The standard recommends that vibration caused by shock, especially quarry blasting, should be measured on the foundation structure parallel to its stiff-axes below ground level.

In only special cases are measurements of floor vibration in the vertical direction and the horizontal vibration of the whole building recommended. Such floor vibration measurements should be made in a manner similar to that of section D.3.

In the case of steady vibration (e.g. floor vibration), the vibration peak velocity, v_{\max} , at the place of highest amplitude should be determined. In floor vibration it is often the midspan, for whole building vibration it is often the upper floor in horizontal direction.

D.4.3.3 Measurement quantity

Vibration can be measured by displacement, velocity or acceleration. It is desirable to measure the quantity that is most simply and generally related to damage as described below. While for steady vibration the proposed standard provides curves related to velocity from 10 Hz to 80 Hz (Figure D-3), it can be seen that for the frequency range of 10 to 80 Hz, acceleration as weighted by the function in Chapter 3 is for all practical purposes a measure of velocity. Plotting the weighted acceleration against actual blast damage data, see Figure D-4, the weighted acceleration provides a very reasonable fit to the data for frequencies below 10 Hz. For these reasons, the use of the weighted acceleration is proposed in the main sections of these guidelines for assessment of impact due to annoyance of building occupants and building damage.

For shock the proposed standard recommends using the vector sum of the maximum velocity along a set of orthogonal axes. The maximum velocity along an axis is that measured at any time during an event. Such an approach will be slightly more conservative than only using the maximum weighted acceleration along the worst case axis. However, the differences between the two approaches

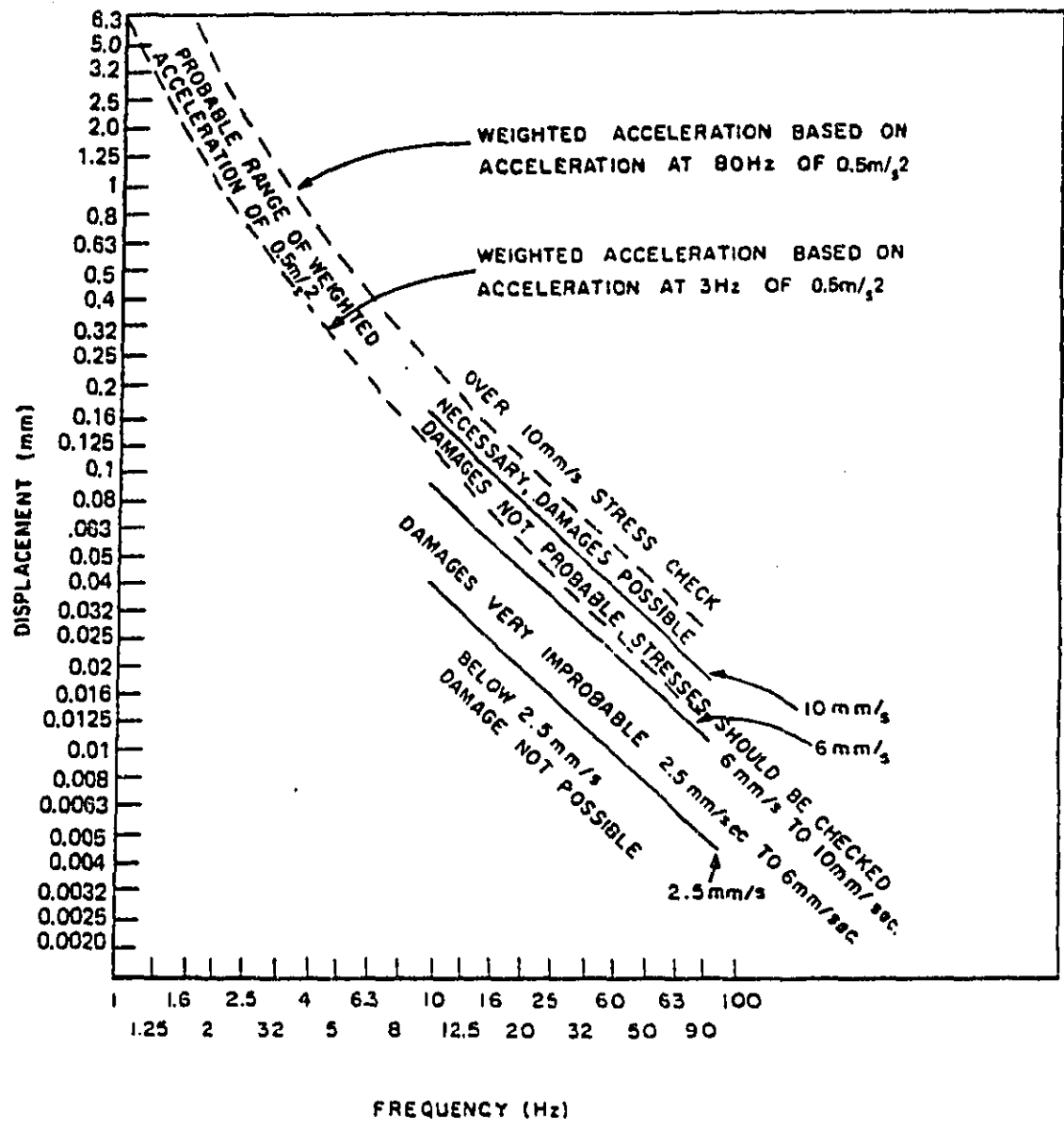

FIGURE D-3. Rough evaluation of vibrations of stationary floor vibrations by measurement of vibration displacements amplitude and frequency

Note: Amplitude is defined here as the maximum absolute value of the displacement of the floor undergoing harmonic motion.

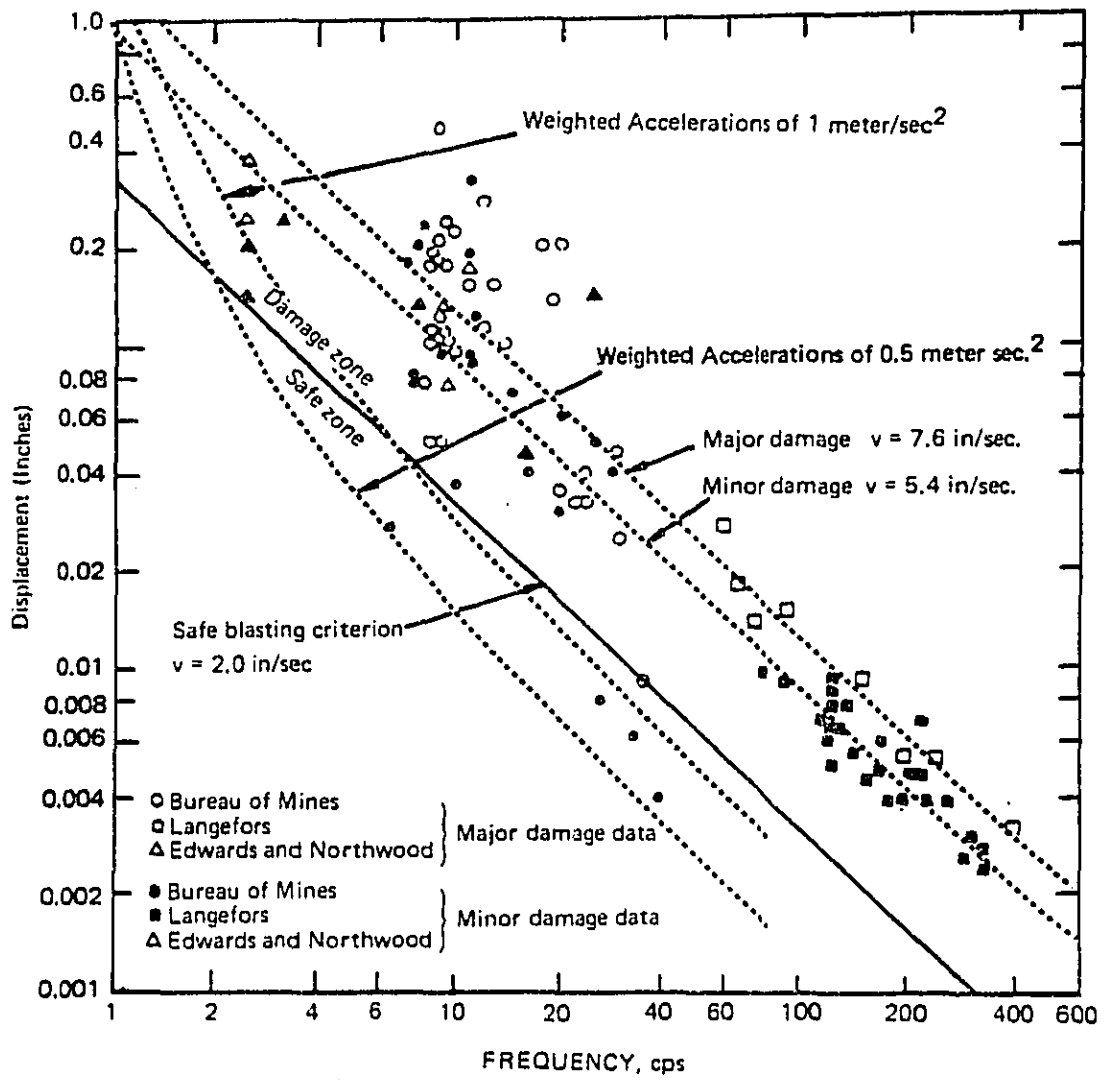

FIGURE D-4. Displacement versus frequency, combined data with recommended safe blasting criterion

is not expected to be great (at the maximum they can only differ by a factor of the square root of 3).

D.4.4 Vibration boundaries with respect to damage categories

D.4.4.1 Vibration caused by shock

In determining criteria for the onset of vibration damage to buildings, the proposed standard indicates a number of factors which can affect the results which are recorded.

These include:

- nature of the soil, clay, or rock, etc.
- stiffness of the building structure
- nature of the vibration, i.e. transient, intermittent, continuous, vertical, horizontal, etc.

With these uncertainties in mind, the proposed standard provides recommendations as to the maximum velocity to prevent damage for each of the three categories. These velocities are listed in Table D-3.

TABLE D-3

Limiting values of the vector sum of the maximum velocities (in three orthogonal axis) caused by quarry-blasting-vibration in dwellings and offices in good physical conditions

<u>Category of Damage</u> <u>(See Section D.4.2)</u>	<u>range V_R, onset of</u> <u>damage, in mm/s</u>
1	3 . . . 5
2	5 . . . 30
3	100

These values are based on measured foundation vibration in the frequency range from about 3 Hz to about 100 Hz.

The standard cautions that:

- (1) In the range between 30 mm/s and 100 mm/s the available data is not sufficient to define the nature of the damage without regard to the condition, type of structure and foundations.
- (2) The limits apply only where differential settlement of the structure has not been excessive.
- (3) Special consideration shall be given where buildings are situated on a slope or on soils which may be compacted or liquified by vibration.
- (4) When large dynamic displacements are found to exist in the whole building or part of it then in addition to the recommended measuring points at the foundation additional measuring points located in the structure shall be used for the evaluation of potential building damage.

The standard recommends that the limits specified in Table D-3 be used for the evaluation of vibration effects caused by pile drivers and forging hammers when the time interval between two successive blows is so large that the vibration of the building due to one blow dissipates before the effects of the succeeding blow are observed. Dissipation is regarded as effective when peak particle velocities have decayed 1/5 from their maximum.

The standard proposed that the values specified in Table D-3 may also be used to evaluate the effects of vibration in buildings caused by traffic; however, when shakers and vibration pile drivers are the source of building vibration, the values given in Table D-3 should not be applied.

Finally, the standard recommends that for the evaluation of transient response of floors and walls, the vibration limits given for steady state

vibrations may be used in a modified form. When there is no danger of fatigue the limits and values given in Figure D-3 may be increased by a factor of 2.

D.4.4.2 Steady vibration of buildings

For steady building vibration, Figure D-3 summarizes the peak velocity boundaries between the different categories of damage.

D.4.5 Comparison of the recommendation of the proposed standard to the recommendations of these guidelines

The proposed standard recommends that 6 mm/s (5 to 30 mm for shock) be considered as the upper limit of the threshold of damage. These velocities are considerably lower than the 2 in/sec (50.8 mm/sec) that has commonly been used in this country. Based on studies such as those shown in Figure D-4, reducing the threshold from 50 mm/sec to 5 mm/sec does not appear warranted, however, reduction of the threshold by a factor of 2 does seem reasonable. All of the data points of Figure D-4 will be covered by use of a velocity of 1 in/sec and it is this velocity that is recommended in the main text of the guidelines. Use of a weighted acceleration of 0.5 m/sec^2 is consistent with this velocity and is recommended.

APPENDIX E

EXAMPLE APPLICATION OF THE GUIDELINE PROCEDURES FOR GENERAL AUDIBLE NOISE

E.1 Proposed highway expansion

This example (presented briefly in section 2.6) concerns a section of highway which runs for several kilometers through a suburban area (Figure E-1). The present two lane roadway is operating at close to capacity, and the proposal is to expand it to six lanes. Although many factors must be considered before undertaking such an expansion, only the noise impacts of the project will be discussed as an illustration of the use of these Guidelines. This example is divided into five sections as follows:

- (1) Statement of the problem
- (2) Using the screening diagram
- (3) Determining the necessary number of figures and tables
- (4) Completing the figures and tables
- (5) Conclusions of the noise analysis

E.1.1 Statement of the problem

From Figure 2 in section 1.3.1, it has been assumed for the purposes of this example that the only concern is general audible noise that may cause an adverse impact. That is, special noises, vibration, and changes in population location are not anticipated to be problems. Tables 6 to 9 in section 2.6 document the project impact over the total area (Figure E-1). However, to illustrate in some detail the use of these Guidelines, this example focuses on a small residential section only, as shown in Figure E-2. Each of the residential buildings consists of two semi-detached townhouse units, with an average population of five persons in each unit, or 50 persons in each row of housing. Additionally, there are four special situations to be considered:

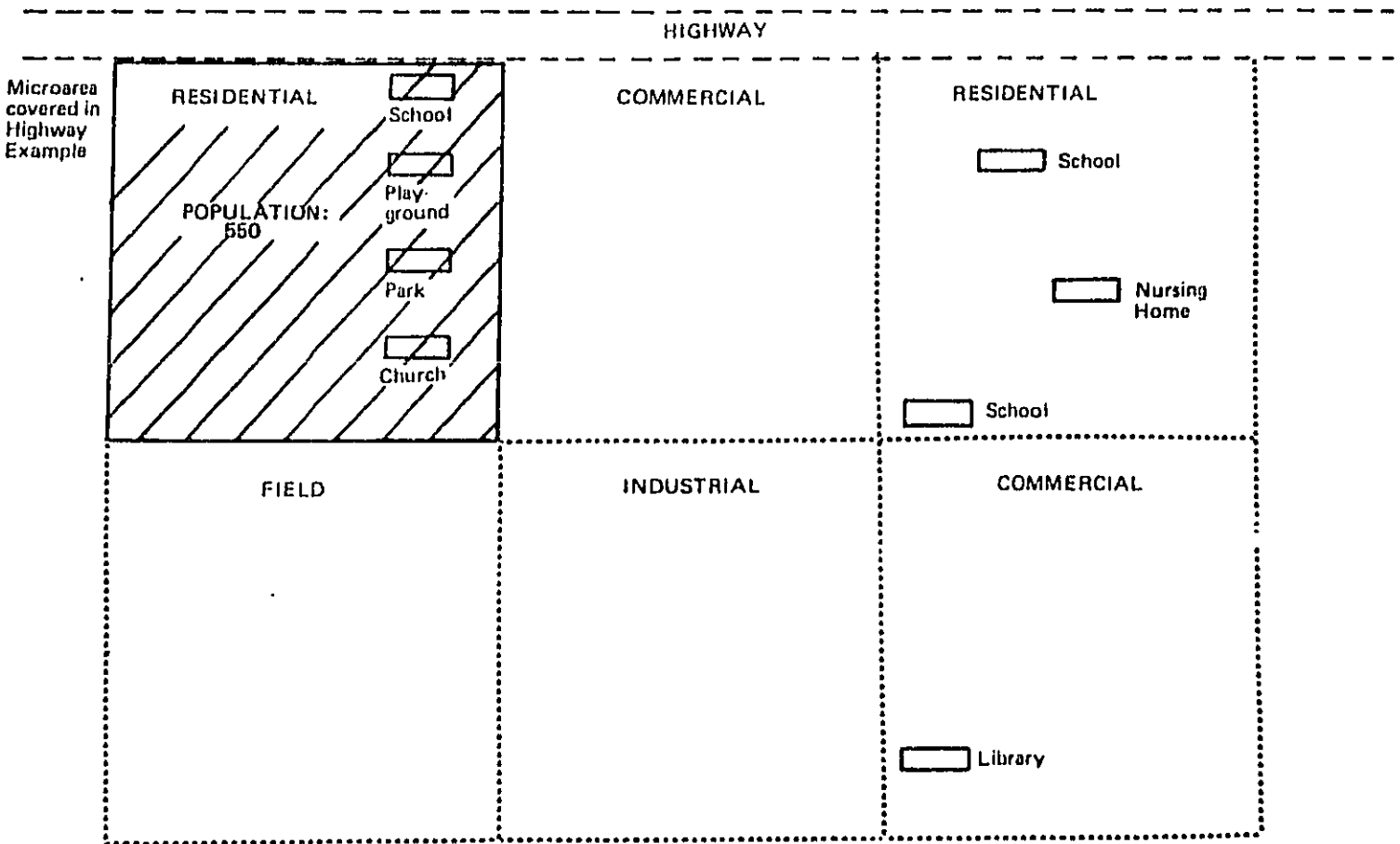

E-2

FIGURE E-1. Highway Expansion Example: Overview

 Area for the specific example

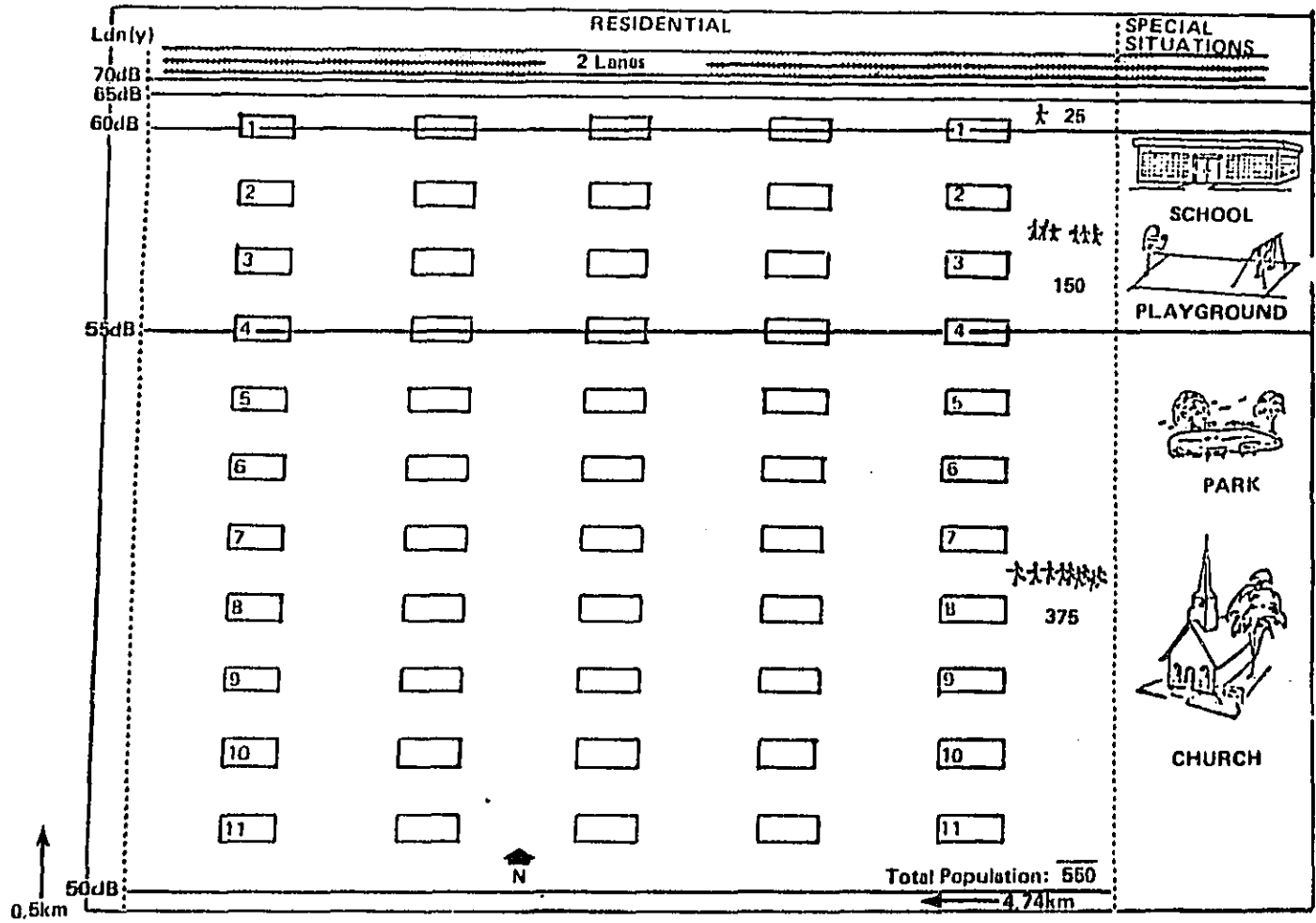

Figure E-2. Sample Data Presentation for the Highway Example: Future Levels Without the Proposed Project

(1) a school with a student-teacher population of 2,500 in attendance 50 weeks a year from 8:00 a.m. to 4:00 p.m.; (2) a playground where 400 children play six hours each day; (3) a park where 160 people relax for one hour each day; and (4) a church where 185 people meet for two hours each day, and 115 people meet for one hour each evening. For a larger project area (such as in Figure E-1), this amount of detail normally would not be obtained. Noise contours would still be plotted, but populations could be estimated from average population densities, census counts, or other such sources as discussed in section 2.1.3. The example is intended to provide an easy-to-follow description of the Guideline procedures.

E.1.2 Using the screening diagram

Is an environmental noise analysis necessary, and if so, what procedures should be followed? Begin by examining the Screening Diagram (Figure E-3, and discussed in section 2.1). This diagram is helpful for determining not only whether a noise impact analysis is necessary, but also what type of analysis should be conducted.*

E.1.2.1 How to use the screening diagram. The values for the "existing $L_{dn}(y)$ " and the "expected L_{dn} of [the] project alone" should be obtained at the location of the noise sensitive land use nearest the project, or the point where the impact of the project is likely to be the greatest. In this example, that point would be the row of duplexes closest to the highway. The existing

*For this example, it is not absolutely necessary to use the screening diagram since it is more or less obvious that some increase in noise will result, and at levels high enough for a full noise environment documentation. However, if in doubt, the screening diagram is a useful aid.

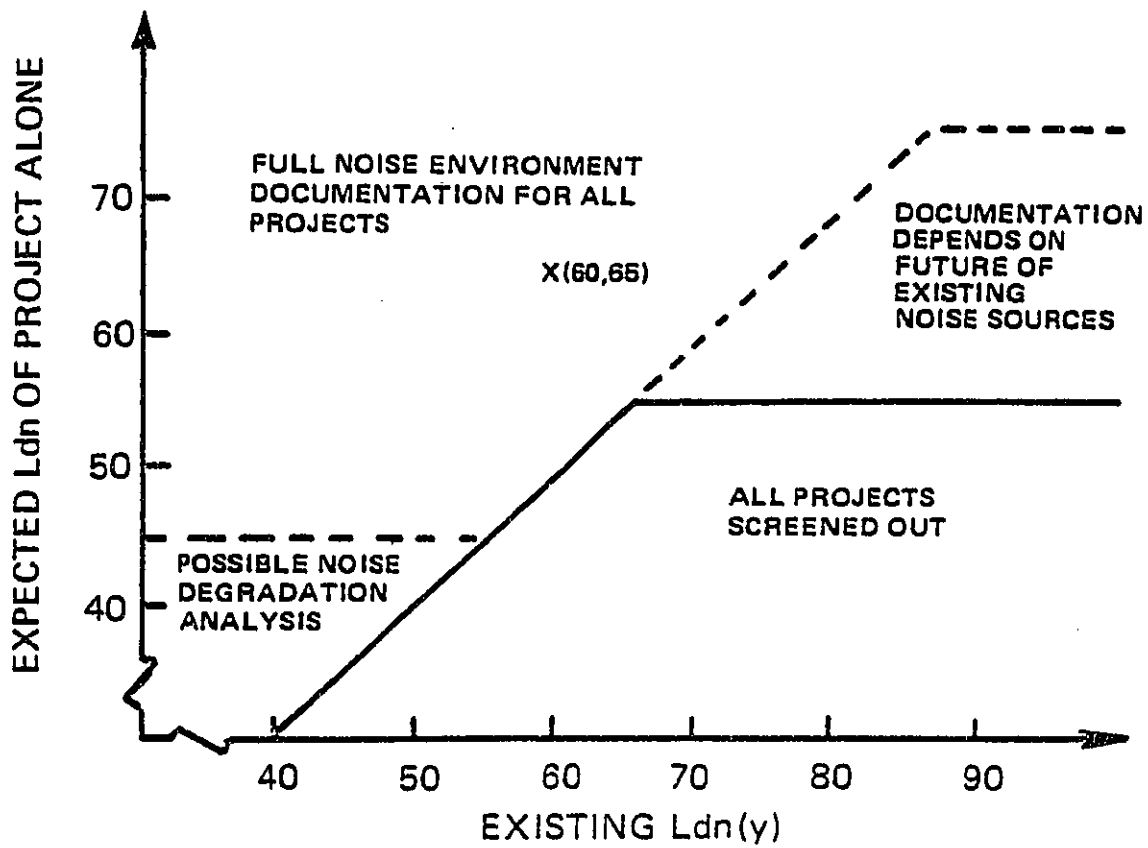

Figure E-3. Screening Diagram: Sample Application

$L_{dn}(y)$ at the closest noise sensitive point may be obtained either by direct measurement or by use of a suitable traffic noise prediction model** as discussed in section 2.1.2. It is assumed that future L_{dn} was obtained through the use of a prediction model. Once the values of "existing $L_{dn}(y)$ " and "future L_{dn} " are obtained, they are plotted as coordinates on the screening diagram (Figure E-3). Their point of intersection (for this example, 60 dB and 65 dB)*** determines both the necessity for and type of noise analysis that should be conducted. In this case, the coordinates fall into the cell that calls for a full noise environment documentation. Therefore, a full noise analysis should be conducted.

E.1.2.2 Other factors to consider before beginning the noise analysis.

As discussed in Chapter 2, there are a few other basic issues which should be considered before beginning the noise analysis:

- o How many projects or alternatives are we considering?
We are considering only one, an expansion from two to six lanes.
- o Will the population of the residential area change in the future?
No, the population will remain the same (by assumption in this example).
- o Is this a temporary project, as defined in section 2.5?
No, this is a long-term project.

**There are in use several models for calculating day-night sound levels based on the type of noise source and operational considerations. These models are available from many sources, some of which are listed at the end of this appendix.

***At the row of houses closest to the highway, the existing $L_{dn}(y)$ of 60 dB is from Figure E-2, and the predicted $L_{dn}(y)$ of 65 dB from the project alone (the 6-lane highway) is from Figure E-4.

- o Will the noise of the project change with time (after the completion of the project)?

No, the noise of the project will remain the same. The immediate demand for the added lanes will be sufficient to fill them to capacity (by assumption in this example).

- o Are existing noise levels in the area low enough that "environmental degradation" is the only concern (as defined in section 2.4)?

No, most of the area will be exposed to project $L_{dn}(y)$ greater than 55 dB. This is confirmed by the screening diagram.

E.1.3 Determining the necessary number of figures and tables. From the discussion in section 2.2.2.a, it is clear that only three sets of contours and corresponding tables are required.*

- o Future levels in the area without the project, i.e., future levels from the existing highway and from residential activities.
- o Future levels due to the proposed project alone, i.e., the six-lane highway alone.**
- o Future levels resulting when the levels from the six-lane highway are combined with the levels generated by other noise sources, i.e., in this case by residential area activities.

*As noted in the text, the population density within the residential area is not expected to change, nor will the noise from the highway change in years subsequent to the proposed expansion. Because these conditions with respect to time are expected to remain constant, additional sets of tables and figures are not necessary. However, if these conditions were to change over time, separate sets of tables should be prepared for (a) the first year of the commencement of the project, (b) twenty years after the expansion (or the latest year for which noise predictions can be reliably made), and (c) the worst case year (if different from the preceding two).

**Note that when the proposed action is an expansion of an existing noise source, the proposed project alone is interpreted to be the expanded project (that is, the six-lane highway), not the amount of expansion (in this case, the additional four lanes).

E.1.4 Completing the figures and tables

The purpose of the analysis is to compare the future noise environment with and without the proposed project. This comparison can be divided into five steps: (1) drawing the noise contours, (2) determining the base area and the base population, (3) transferring the data to the tables, (4) calculating the single-number comparison indices; and (5) noting special populations.

E.1.4.1 Drawing the noise contours. As discussed in section E.1.3, three sets of contours and tables are required. For purposes of this example, it is assumed that contours describing the future noise environment in the area without the highway expansion have been obtained by measurement, since in this example future levels are the same as existing levels. It is also assumed that the noise levels from the future six-lane highway alone have been obtained from a suitable highway noise prediction model. These results are illustrated in Figures E-2 and E-4, respectively.

To draw contours reflecting the combined future noise environment from the project levels and levels generated from residential activity requires additional information, that is, knowledge of residential area levels in the absence of any highway noise. This information can be obtained in two ways. An estimate can be made on the basis of population density using equation 1 in section 2.1.1. Or, measurements can be taken at a large distance from the road (for example, where noise from the roadway is no longer clearly noticeable), as long as the nature of the area is not expected to change in the future. The background residential noise levels derived above (assumed to be about 50 dB in this example) are then combined on a point-by-point basis with the project alone levels presented in Figure E-4 to derive

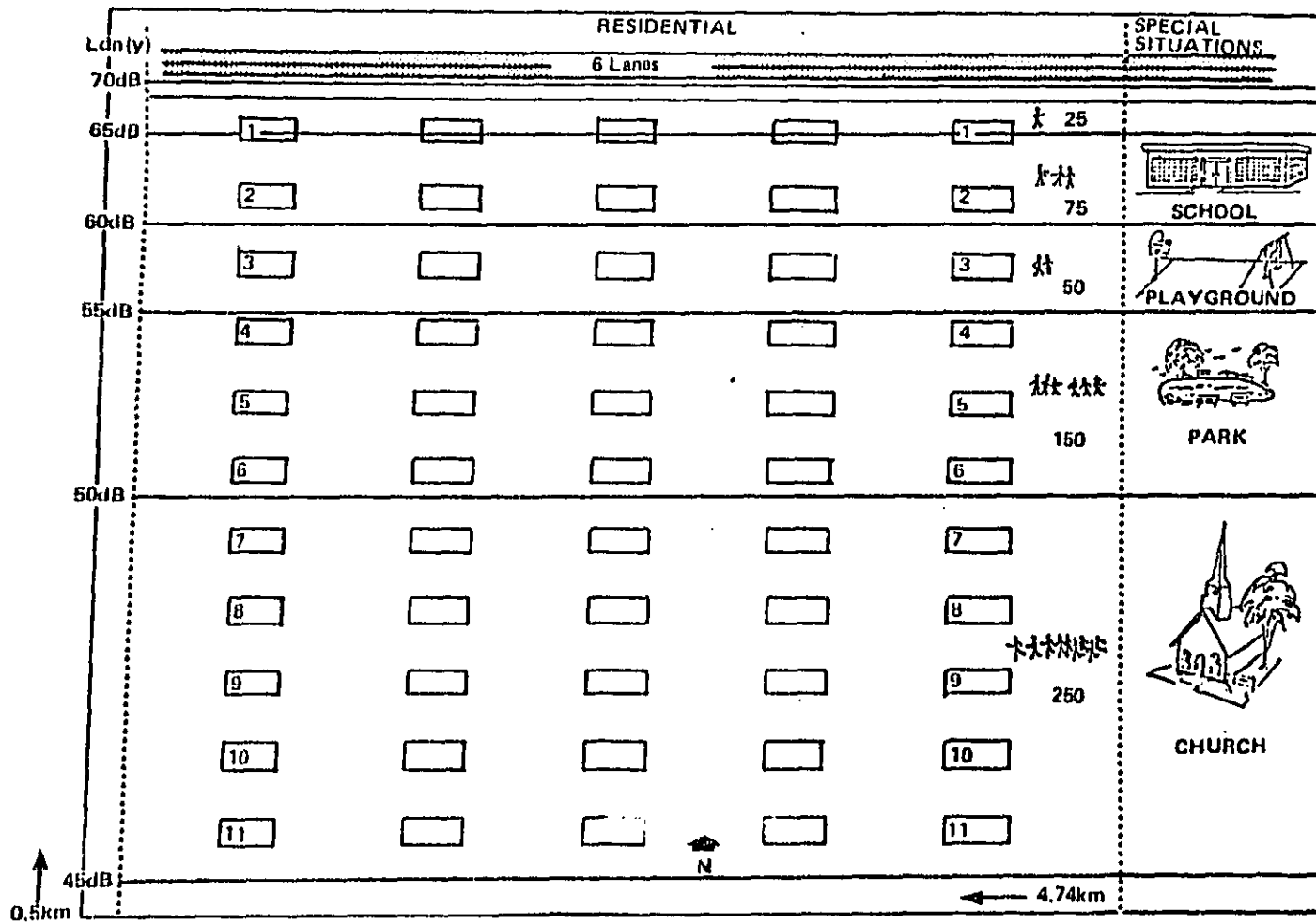

Figure E-4. Sample Data Presentation for the Highway Example: Future Noise Levels from the Project Alone

E-9

DRAFT REPORT

contours depicting the total future noise environment (project plus background) as shown in Figure E-5.*

E.1.4.2 Determining the base area and base population. As noted in section 2.1.3, the base population is defined as the number of people living in areas with outdoor noise levels produced by the project alone above a specified L_{dn} value. This is called the base L_{dn} . The base L_{dn} is determined by reference to the existing yearly L_{dn} contours in the residential area (Figure E-2). The lowest L_{dn} in the residential area is about 50 dB near the back row of houses. Therefore, from section 2.1.3, the optimum base L_{dn} to use, if possible, in order to define the base population is 40 dB (that is, 10 dB below the existing $L_{dn}(y)$). Next, we examine Figure E-4 which shows the noise contours from the project alone. Applying the base $L_{dn} = 40$ dB, we can derive the base area. In this example, none of the residents are living in areas where the outdoor yearly day-night sound levels are below 45 dB (i.e., no people live within the 40-45 dB interval). Thus, the next best thing is to effectively define the base area as the area exposed above $L_{dn}(y) = 45$ dB. In this case, there is only one proposed project, and the base population is 550 people, in an area of 2.37 sq. km. (Fig. E-4).

E.1.4.3 Transferring the data to the tables. Tabulations of population and area exposure information are provided in Tables E-1, E-2, and E-3 for Figures E-2, E-4, and E-5, respectively. The values in the tables are derived by summing the number of people and land area within each five decibel band. If a

*For a step-by-step explanation of the combination process, see the discussion at the end of this appendix. Note also that the combination process may result in contour lines in other than the desirable five decibel intervals. Interpolation may be necessary to plot the information in the five decibel bands.

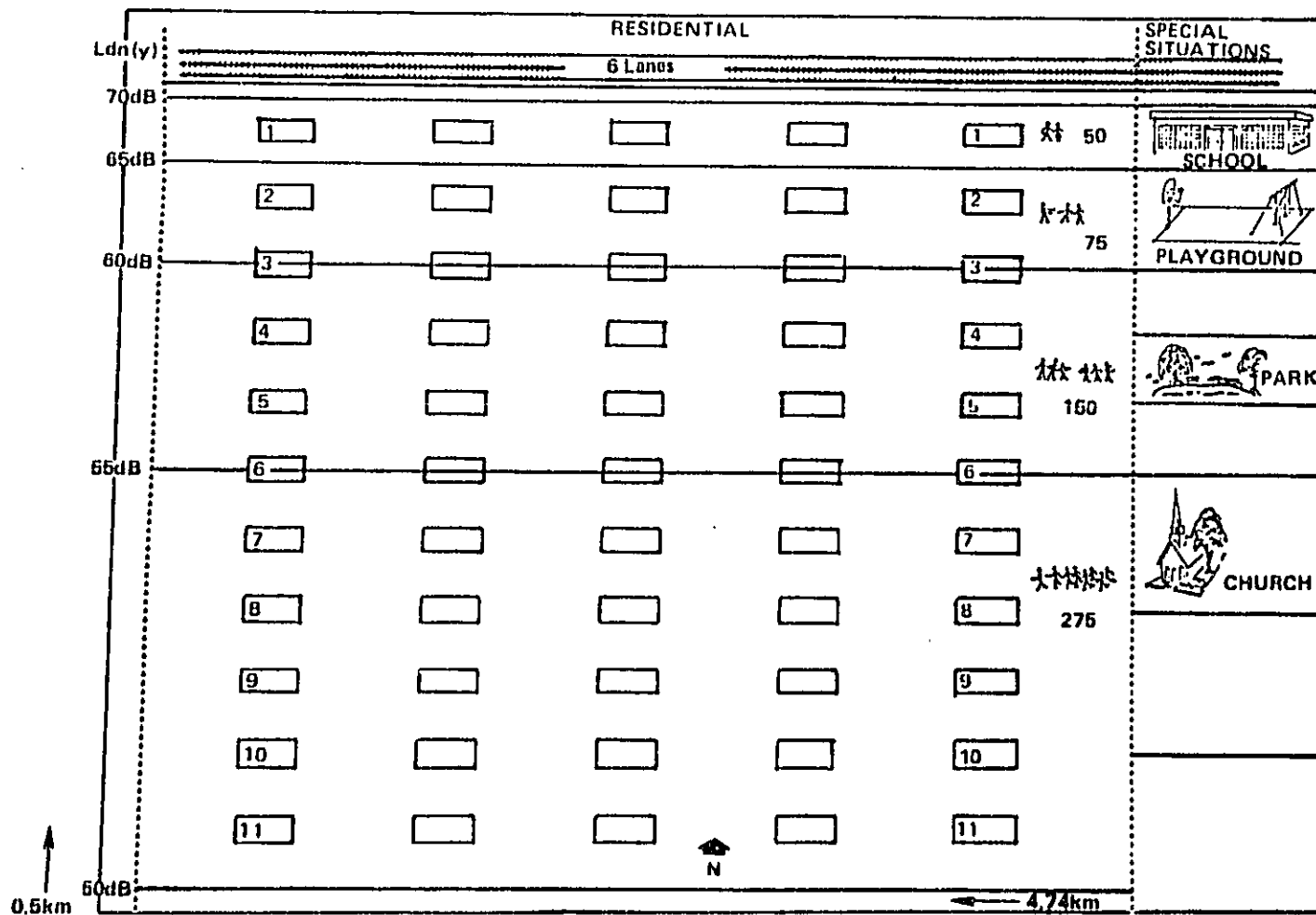

Figure E-5. Sample Data Presentation for the Highway Example: Future Levels from All Noise Sources Combined

contour line bisected a row of duplexes, the residents were divided between the noise bands. For example, from Figure E-5:

<u>Noise band ($L_{dn}(y)$)</u>	<u>Number of People</u>
65 - 70 dB	50
60 - 65 dB	75
55 - 60 dB	150
50 - 55 dB	275

E.1.4.4 Calculating the single-number indices. For this comparison, three measures of impact should be considered: (1) the sound level weighted population (LWP); (2) the noise impact index (NII); and (3) the relative change in impact (RCI).* The indices LWP and NII should be computed for each of the tables (Tables E-1 thru E-3). For purposes of illustration, detailed calculations will only be shown for Table E-1.

Calculation of the level weighted population was based on the values of the weighting function of equation 2b, shown in Table 3 of the main text. Thus, using equation 6:

$$\begin{aligned}
 \text{LWP} &= [P(65-70) \times W(67.5)] + [P(60-65) \times W(62.5)] + \\
 &\quad [P(55-60) \times W(57.5)] + [P(50-55) \times W(52.5)] + \\
 &\quad [P(45-50) \times W(47.5)] \\
 &= [(0) \times (0.194)] + [(25) \times (0.116)] + \\
 &\quad [(150) \times (0.064)] + [(375) \times (0.032)] + \\
 &\quad [(0) \times (0.015)] \\
 &= 24.5 \approx 24 \text{ people}
 \end{aligned}$$

*In this example, since there are no outdoor exposures greater than $L_{dn} = 75$ dB, it is extremely unlikely that there will be any at-ear $L_{eq}(24)$ exposure greater than 70 dB. Therefore, we need not consider the single-number indices for severe health effects (hearing-loss weighted population and average potential hearing loss) as discussed in section 2.3.

TABLE E-1

SAMPLE DATA PRESENTATION FOR THE HIGHWAY EXAMPLE: FUTURE LEVELS WITHOUT PROPOSED PROJECT

Yearly L_{dn} (dB)	Residential Population	Residential Land Area (Sq km)	Industrial/Commercial Land Area (Sq km)	Total Land Area (Sq km)	Special Situations (See Table E-4)
>70	0	0	0	0	-
65-70	0	0.087	0	0.087	-
60-65	25	0.107	0	0.107	-
55-60	150	0.646	0	0.646	1,2
50-55	375	1.530	0	1.530	3,4
45-50	0	0	0	0	-
	<u>550</u>	<u>2.370</u>		<u>2.370</u>	

Level Weighted Population (LWP) = 24

Noise Impact Index (NII) = 0.044

Hearing-Loss Weighted Population (HWP) = 0

Average Potential Hearing Loss (PHL) = 0

Corresponds to Fig. E-2

Includes: o Self-generated neighborhood noise.

o Levels of noise from the existing two-lane highway.

TABLE E-2

SAMPLE DATA PRESENTATION FOR THE HIGHWAY EXAMPLE: FUTURE NOISE LEVELS OF PROJECT ALONE

Yearly L_{dn} (dB)	Residential Population	Residential Land Area (Sq km)	Industrial/ Commercial Land Area (Sq km)	Total Land Area (Sq km)	Special Situations (See Table E-4)
>70	0	0	0	0	-
65-70	25	0.1232	0	0.1232	-
60-65	75	0.2702	0	0.2702	1
55-60	50	0.2465	0	0.2465	2
50-55	150	0.3982	0	0.3982	3
45-50	250	1.3320	0	1.3320	4
	<u>550</u>	<u>2.370</u>		<u>2.370</u>	

Level Weighted Population (LWP) = 25

Noise Impact Index (NII) = 0.045

Hearing-Loss Weighted Population (HWP) = 0

Average Potential Hearing Loss (PHL) = 0

Corresponds to Fig. E-4

Includes: o Levels of noise
from the proposed
six-lane highway.

TABLE E-3

SAMPLE DATA PRESENTATION FOR THE HIGHWAY EXAMPLE: FUTURE LEVELS FROM ALL NOISE SOURCES COMBINED

Yearly L _{dn} (dB)	Residential Population	Residential Land Area (Sq km)	Industrial/Commercial Land Area (Sq km)	Total Land Area (Sq km)	Special Situations (See Table E-4)
>70	0	0	0	0	-
65-70	50	0.1232	0	0.1232	1
60-65	75	0.2465	0	0.2465	1,2
55-60	150	0.6716	0	0.6716	3
50-55	275	1.3830	0	1.3830	4
45-50	0	0	0	0	-
	<u>550</u>	<u>2.370</u>		<u>2.370</u>	

E-15

Level Weighted Population (LWP) = 37

Corresponds to Fig. E-5

Noise Impact Index (NII) = 0.067

Hearing-Loss Weighted Population (HWP) = 0

Includes: o Self-generated neighborhood noise.
o Levels of noise from the six-lane highway.

Average Potential Hearing Loss (PHL) = 0

The Noise Impact Index, according to equation 7 in section 2.2.2.c, is simply LWP divided by the total (base) population. Thus:

$$NII = \frac{LWP}{P_{Total}} = \frac{24}{550} = 0.044$$

From equation 8, the Relative Change in Impact between the case without the proposed expansion (Table E-1) and the case with the expansion (Table E-3) is computed as:

$$RCI = \frac{LWP_a - LWP_b}{LWP_b} = \frac{37 - 25}{25} = 48\%$$

E.1.4.5 Noting special populations. Special populations do not affect the calculation of the single-number indices. However, they are noted on the figures and tables to give the reader additional information about the affected area. As discussed in Section 2.2.2.a., the time weighted average number of people present at these special locations during the year may be computed as:

$$\frac{(\text{number of people}) \times (\text{time the people are present during the year})}{(\text{number of hours in a year})}$$

For the school in our example where 2,500 students and faculty use the school eight hours a day, five days a week, forty weeks a year:

$$\frac{(2,500 \text{ student and teachers}) \times (8 \text{ hours}) \times (5 \text{ days}) \times (40 \text{ weeks})}{8,760 \text{ hours in a year}} = 457 \text{ people.}$$

For the playground where 400 children play six hours each day:

$$\frac{(400 \text{ children}) \times (6 \text{ hours}) \times (7 \text{ days}) \times (52 \text{ weeks})}{8,760 \text{ hours in a year}} = 100 \text{ people.}$$

For the park where 160 people relax for one hour per person each day:

$$\frac{(160 \text{ people}) \times (1 \text{ hour}) \times (7 \text{ days}) \times (52 \text{ weeks})}{8,760 \text{ hours in a year}} = 7 \text{ people.}$$

For the church where 185 people meet for two hours each day, and 115 people meet for one hour each night, consider the day and night population separately:

$$\frac{(185 \text{ people}) \times (2 \text{ hours}) \times (7 \text{ days}) \times (52 \text{ weeks})}{8,760 \text{ hours in a year}} = 15 \text{ people.}$$

$$\frac{(115 \text{ people}) \times (1 \text{ hour}) \times (7 \text{ days}) \times (52 \text{ weeks})}{8,760} = 5 \text{ people.}$$

The results for special populations are depicted in Table E-4.

TABLE E-4
 SAMPLE DATA PRESENTATION: SPECIAL SITUATIONS

	Average population		Range of L _{dn} (y)		<u>Comments</u>
	<u>Day</u>	<u>Night</u>	<u>Current</u>	<u>Future with Project</u>	
1. Elementary school	457	0	55-60 dB	60-70 dB	Good acoustic insulation
2. School playground	100	0	55-60 dB	60-65 dB	-
3. Park	7	0	50-55 dB	55-60 dB	-
4. Church	15	5	50-55 dB	50-55 dB	Evening meetings

E.2 Proposed airport runway addition

This example concerns the addition of a runway at an angle to an existing runway. The addition will be completed in 1985. After 1985, airport operation and noise will increase until maximum levels are attained in 2001. Bordering the airport are a high and a low population density neighborhood. Both neighborhoods will encroach on the airport between 1985 and 2001, as is shown in Fig. E-6. The rest of the land near the airport is zoned commercial/industrial. Although many factors must be considered before undertaking an airport expansion, only the noise impacts will be discussed in order to illustrate the use of the Guidelines.

This example is divided into five sections:

- (1) Statement of the problem
- (2) Using the screening diagram
- (3) Determining the necessary number of figures and tables
- (4) Completing the figures and tables
- (5) Conclusions of the noise analysis

E.2.1 Statement of the problem

From Figure 2 in section 1.3.1, it has been assumed for the purposes of this example that the only concern is general audible noise that may cause an adverse or potentially severe impact. That is, special noises and vibration are not anticipated to be problems. To illustrate in some detail the use of these Guidelines, this example focuses on the potential noise impact upon each of the residential areas in proximity to the airport as shown in Figure E-6. It is assumed that the number of people living within each of these neighborhoods is computed or estimated from census counts, average population densities or other methods discussed in section 2.1.3.

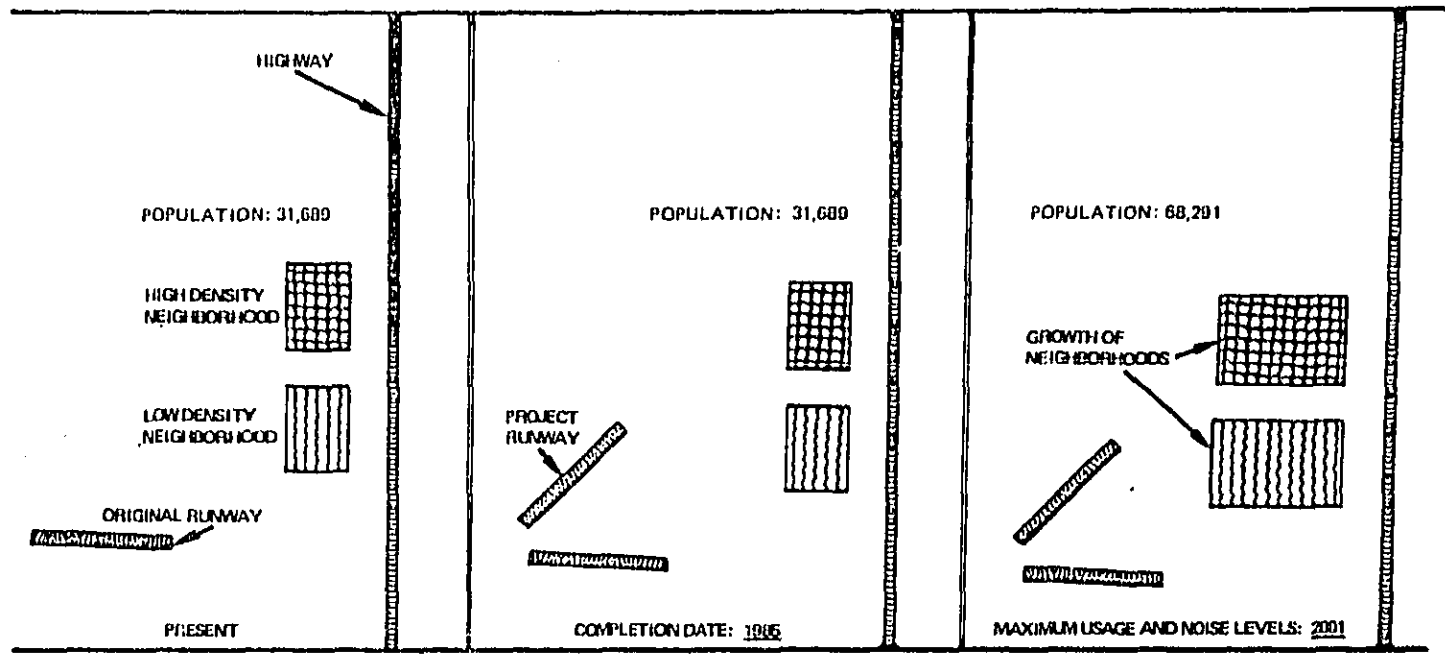

Figure E-6. Sample Data Presentation for the Airport Example: Schematic of the Existing Situation, 1985, and 2001. (Note the Addition of the Project Runway and the Encroachment of the Neighborhoods.)

E.2.2 Using the screening diagram

Is an environmental noise analysis necessary, and if so, what analytical procedures should be followed? Begin by examining the Screening Diagram (Figure E-7 and explained in section 2.1). This diagram is helpful for determining not only whether a noise impact analysis is necessary, but also what type of analysis should be conducted.*

E.2.2.1 How to use the screening diagram. The values for the "existing $L_{dn}(y)$ " and the "expected L_{dn} of [the] Project Alone" should be obtained at the location of the noise sensitive land used nearest the project, or the point where the impact of the project is likely to be the greatest. Relevant noise level data is contained within Figures E-8 and E-9, respectively. Because, as previously noted, airport noise will be greatest in the year 2001, the point of greatest impact is taken from Figure E-9. In this example, the point where the impact of the project is likely to be the greatest is in the high population density neighborhood, and is designated on Figure E-9 by the mark "X". The $L_{dn}(y)$ at that location from the airport alone will be about 81 dB.** Note that, in this example, the point of Greatest impact is not

*For this example, it is not absolutely necessary to use the Screening Diagram since it is more or less obvious that some increase in noise will result, and at levels high enough for a full noise environment documentation. However, if in doubt, the screening diagram is a useful aid.

**The "Future Noise Levels of Project Alone; 2001" (Fig. E-9) was determined by using a computer model, as discussed in section 2.1.2. There are several models for calculating day-night sound levels based on the type of noise source and operational considerations. These models are available from many sources, some of which are listed at the end of this appendix. These models were also used to predict all of the other future L_{dn} noise values in this example (except where otherwise noted).

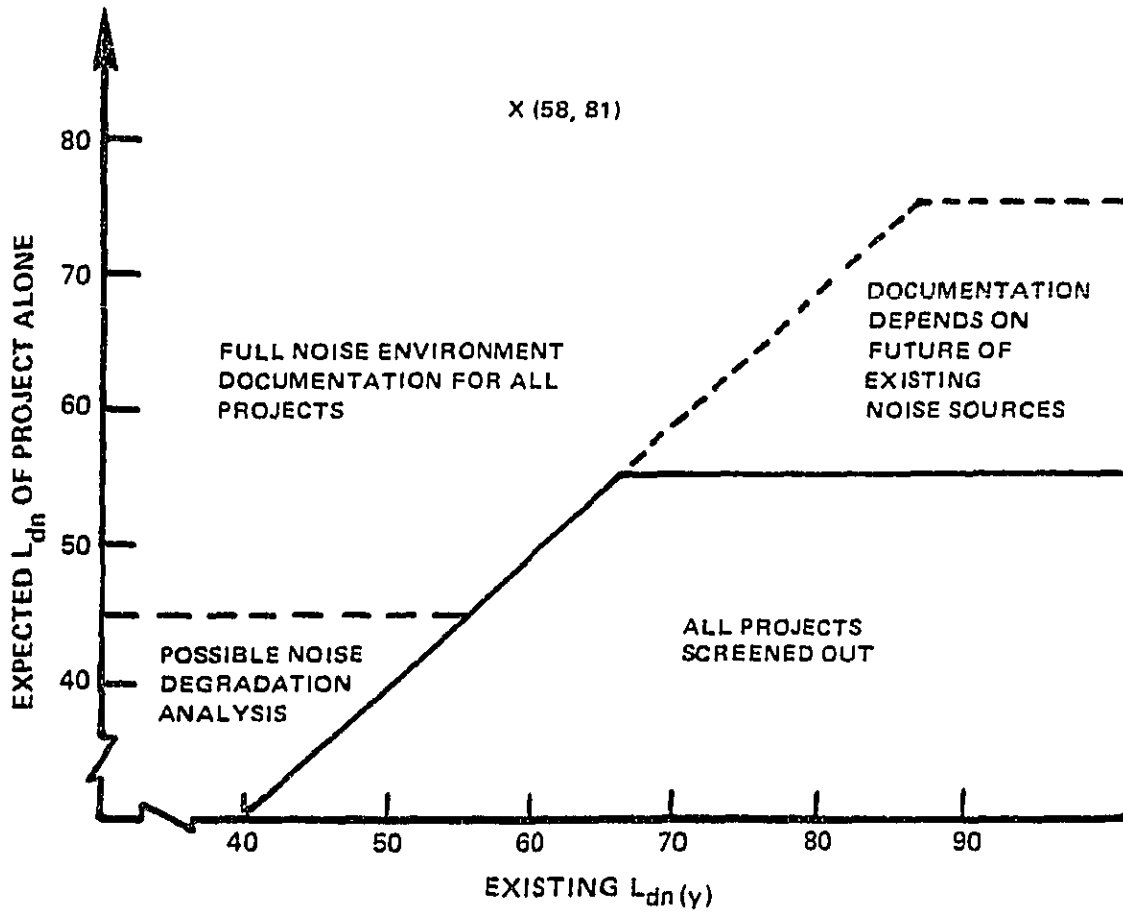

Figure E-7. Screening Diagram

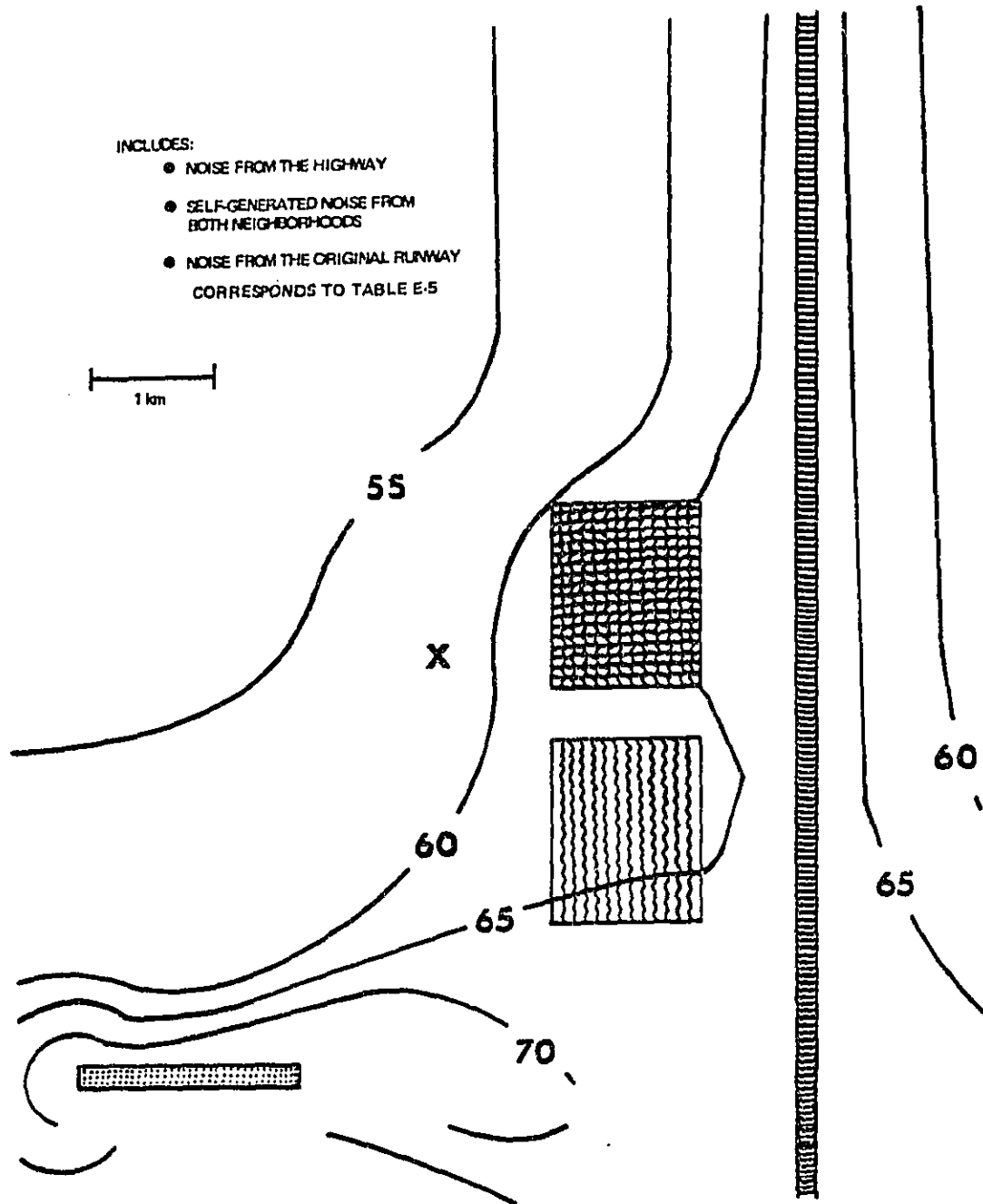

Figure E-8, Sample Data Presentation for the Airport Example: Existing $L_{dn}(y)$

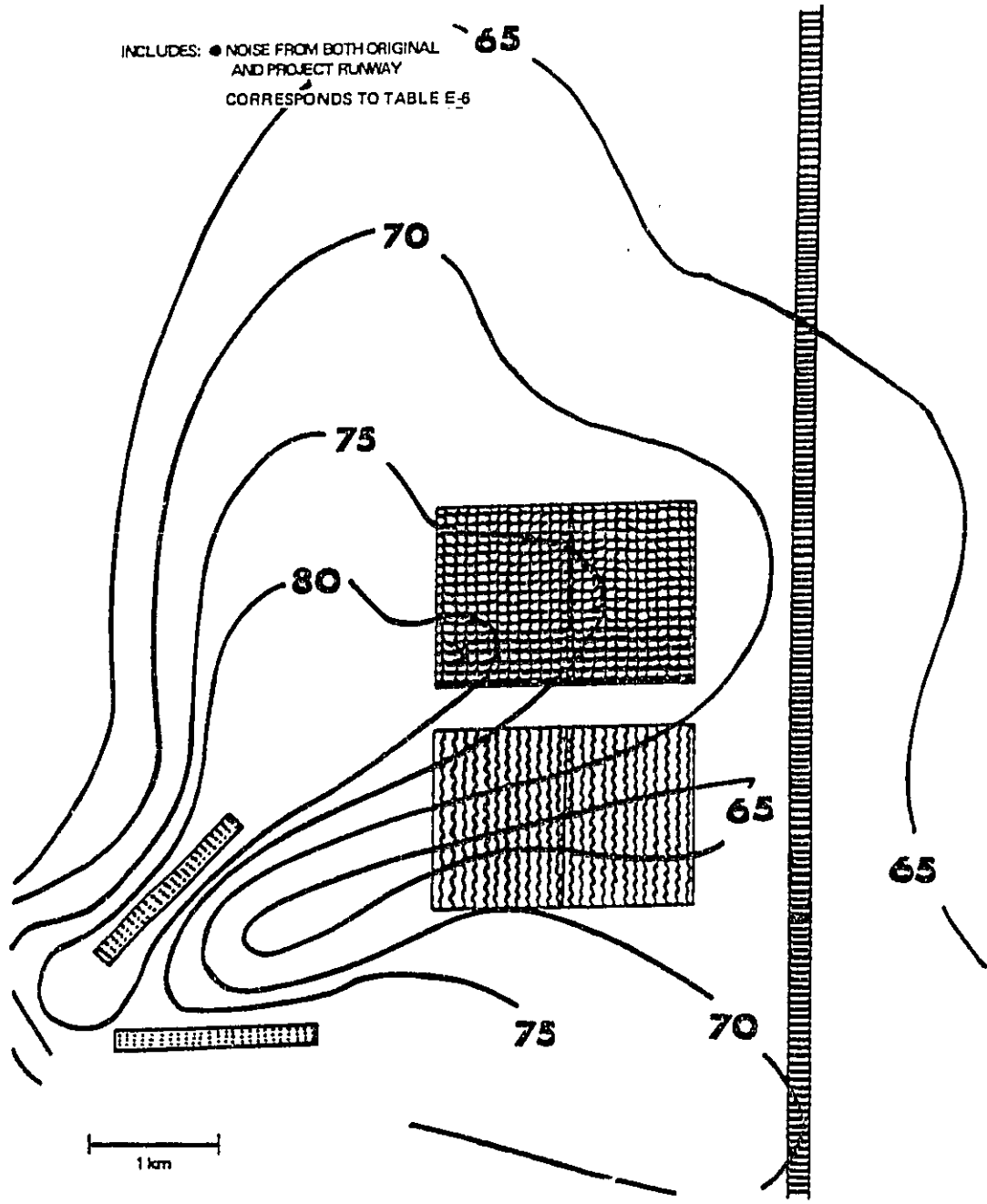

Figure E-9. Sample Data Presentation for the Airport Example: Future Noise Levels of the Project Alone; 2001

the closest noise sensitive location. The noise level at the corresponding point on Figure E-8 is approximately 58 dB.*

Once the values of the "Existing $L_{dn}(y)$ " and the "Expected L_{dn} of the Project Alone" are obtained, they are plotted as coordinates on the screening diagram (Fig. E-7). Their point of intersection (for this example, 58 dB and 81 dB) determines both the necessity for, and type of, noise analysis that should be conducted. In this case, the coordinates fall into the cell that calls for a full noise environment documentation. Therefore, a full noise analysis should be conducted.

E.2.2.2 Other factors to consider before beginning the noise analysis. As discussed in Chapter 2, there are a few other basic issues which should be considered before beginning the noise analysis:

- o How many projects are we considering?

We are considering only one option, the addition of a runway with an increase in total airport operations.

- o Will the population of the residential areas remain the same?

No, between the years 1985 and 2001 both residential areas will increase in population and size. In the existing situation, the self-generated (ambient) noise levels in the low density neighborhood (780 people per square kilometer) is estimated to be 55 dB. By assumption, the number of people in the low density area will remain the same until 1985. By the year 2001, even though the population will increase, the ambient

*For purposes of this example, the "Existing $L_{dn}(y)$ " (Fig. E-8) was assumed to have been determined by direct measurement as discussed in section 2.1.2.

noise levels* will remain the same because the population density (people per square kilometer) will remain constant. In the high density neighborhood, the existing and future ambient is estimated to be 65 dB (7,700 people per square kilometer).

- o Is this a temporary project, as defined in section 2.5?

No, this is a long-term project.

- o Will the noise of the project change with time (after the completion of the project in 1985)?

Yes, as previously stated, the noise levels will be increasing between 1985 and 2001, reaching a maximum in the year 2001. The increase in noise is caused by an increase in airport operations.

- o Are existing noise levels in the area low enough that "environmental degradation" is the only concern (as defined in section 2.4)?

No, surrounding the airport is a commercial/industrial area with a background $L_{dn}(y)$ of 55 dB in many locations. Such a high background noise level when plotted on the screening diagram is outside of the cell concerning low noise areas. (This cell is entitled "Possible Noise Degradation Analysis.")

- o Are there any special situations (as explained in section 2.2.2), such as religious facilities, outdoor auditoriums, schools, precision laboratories or hospitals?

By assumption in this example, there are no special situations.

*Yearly day-night sound levels as estimated from population densities are discussed in Section 2.1.2.

E.2.3 Determining the necessary number of figures and tables

From the discussion in section 2.2.2.a, it is clear that a number of sets of contours and corresponding tables are necessary.

- o Existing noise levels
- o Future levels without proposed project; 1985
- o Future levels with the proposed project alone; 1985
- o Future levels from all noise sources combined; 1985
- o Future levels without proposed project; 2001
- o Future levels with the proposed project alone; 2001*
- o Future levels from all noise sources combined; 2001

E.2.3.1. Completing the figures and tables. The purpose of the analysis is to compare the future noise environment with and without the proposed project. This comparison can be divided into four steps: (1) drawing the noise contours; (2) determining the base area and the base population; (3) transferring the data to the tables; and (4) calculating the single number comparison indices.

E.2.3.1 Drawing the noise contours. As discussed in section E.2.3, a number of sets of contours and tables are necessary. For purposes of this example, it is assumed that the future noise levels of the project have been obtained from a suitable airport noise prediction model taking into account the new generation of quieter aircraft. To draw contours reflecting the combined future noise environment from the project levels and levels generated from

*Note that when the proposed action is an expansion of an existing facility, the proposed project alone is interpreted to be the expanded project (that is, both the old and new runways), not the expansion alone (in this case, the new runway alone).

residential activity requires additional information. A knowledge of residential area levels in absence of any other noise (such as highway or airport noise) is necessary. This information can be obtained in two ways. An estimation can be made on the basis of population density using equation 1 from section 2.1.2, or measurements can be taken at a large distance from the other noise sources. In this example, the former method was used, as discussed in section E.2.2.2.

The necessary illustrations are discussed below:

- o Figure E-8: Existing levels and future noise levels without the proposed project; 1985

The noise levels in 1985 without the project are the same as the noise levels in the existing situation. This lack of change is by assumption in this example.

- o Figure E-10: Future noise levels of the project alone; 1985

- o Figure E-11: Future levels from all noise sources combined; 1985
The data contained in Figures E-8 and E-10 are combined to create contours of total noise exposure.*

- o Figure E-12: Future levels without the proposed project; 2001

This represents the noise intrinsic to the neighborhood which is expanded, the highway, and levels of noise from the increased usage of the existing single runway.

**Logarithmic combinations are discussed at the end of this appendix.

- o Figure E-9: Future noise levels of the project alone; 2001
 - o Figure E-13: Future levels from all noise sources combined; 2001
- The data contained in Figures E-9 and E-12 are combined to create contours of total noise exposure.*

E.2.4.2 Determining the base area and base population. As noted in section 2.1.3, the base population is defined as the number of people living in areas with outdoor levels of noise produced by the project alone above a specified L_{dn} value. This is called the base L_{dn} . The base L_{dn} is determined by reference to the existing yearly L_{dn} contours in the residential area (Figure E-8). From Figure E-8, the lowest L_{dn} in the residential area is about 60 dB. Therefore, from section 2.1.3, the optimum base L_{dn} to use, if possible, in order to define the base population is 50 dB (that is, 10 dB below the existing $L_{dn}(y)$). Next, we examine Figure E-9 which shows the noise contours from the proposed project alone in 2001 (the year with the greatest impact). Applying the base $L_{dn} = 50$ dB, the base area should be the area within the 50 dB contour. However, since the level of ambient noise is assumed to be at least 55 dB, such a base area would extend far beyond the boundaries of Figure E-9. In fact, the land within the 55 dB contour also extends well beyond the boundaries of the figure. Since there are by assumption no other residential areas in the vicinity, it is not necessary to choose such a large base area. Instead, it would be more logical to consider as the base population the people residing within the residential areas of interest.

*Logarithmic combinations are discussed at the end of this appendix.

INCLUDES:
● NOISE LEVELS FROM BOTH ORIGINAL AND PROJECT RUNWAYS
CORRESPONDS TO TABLE E-7

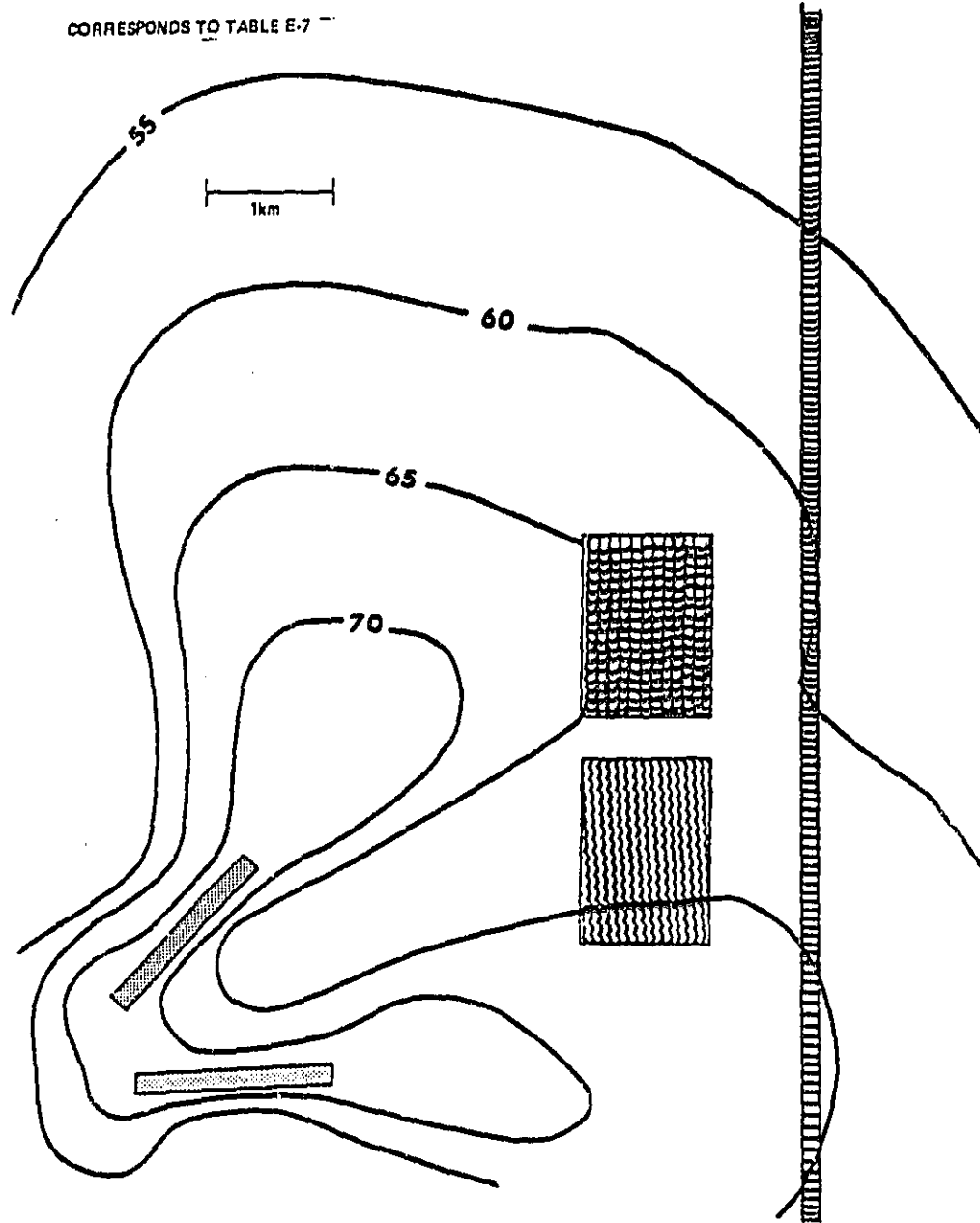

Figure E-10. Sample Data Presentation for Airport Example: Future Noise Levels of the Project Alone; 1985

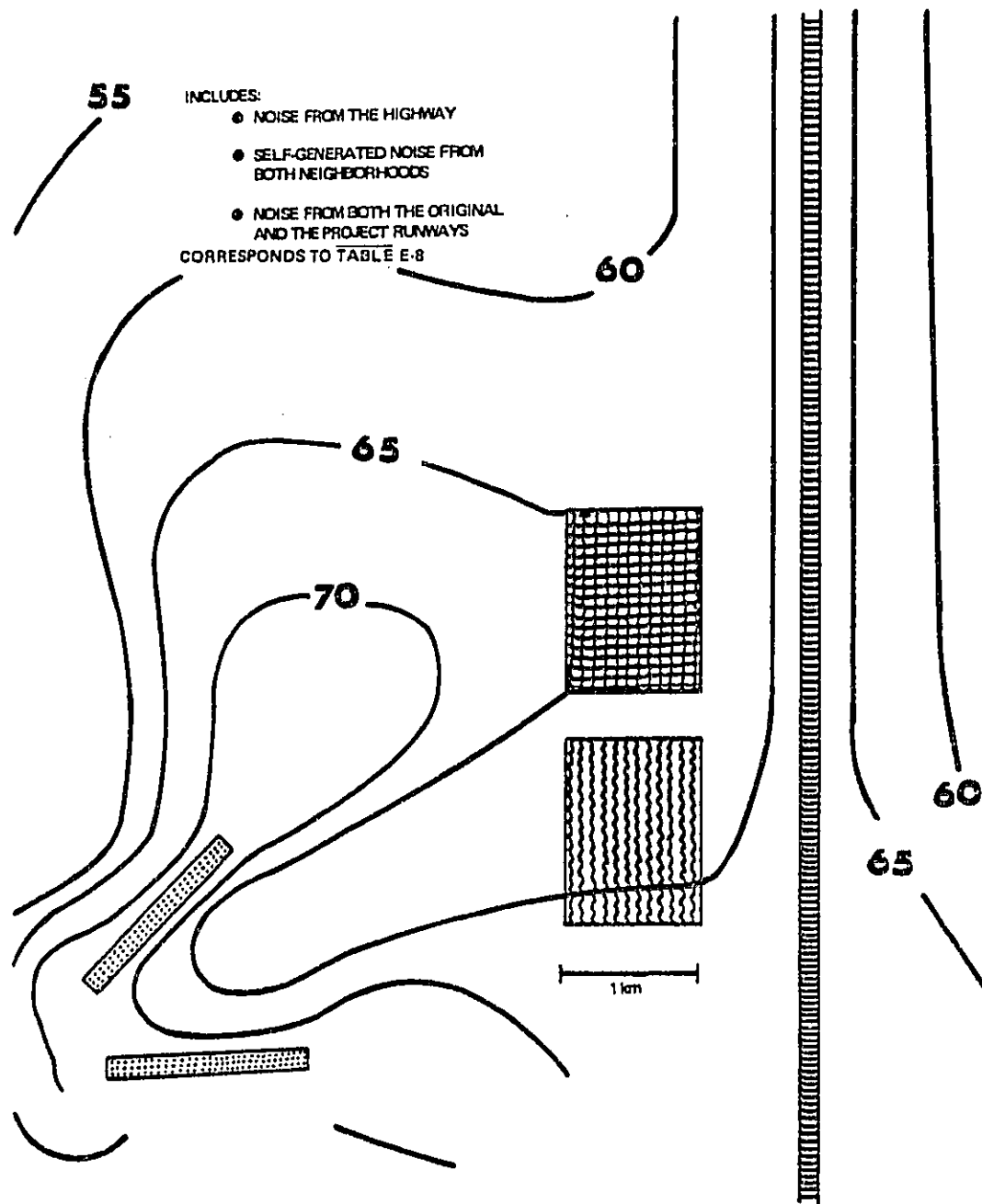

Figure E-11. Sample Data Presentation for the Airport Example: Future Levels from All Noise Sources Combined; 1985

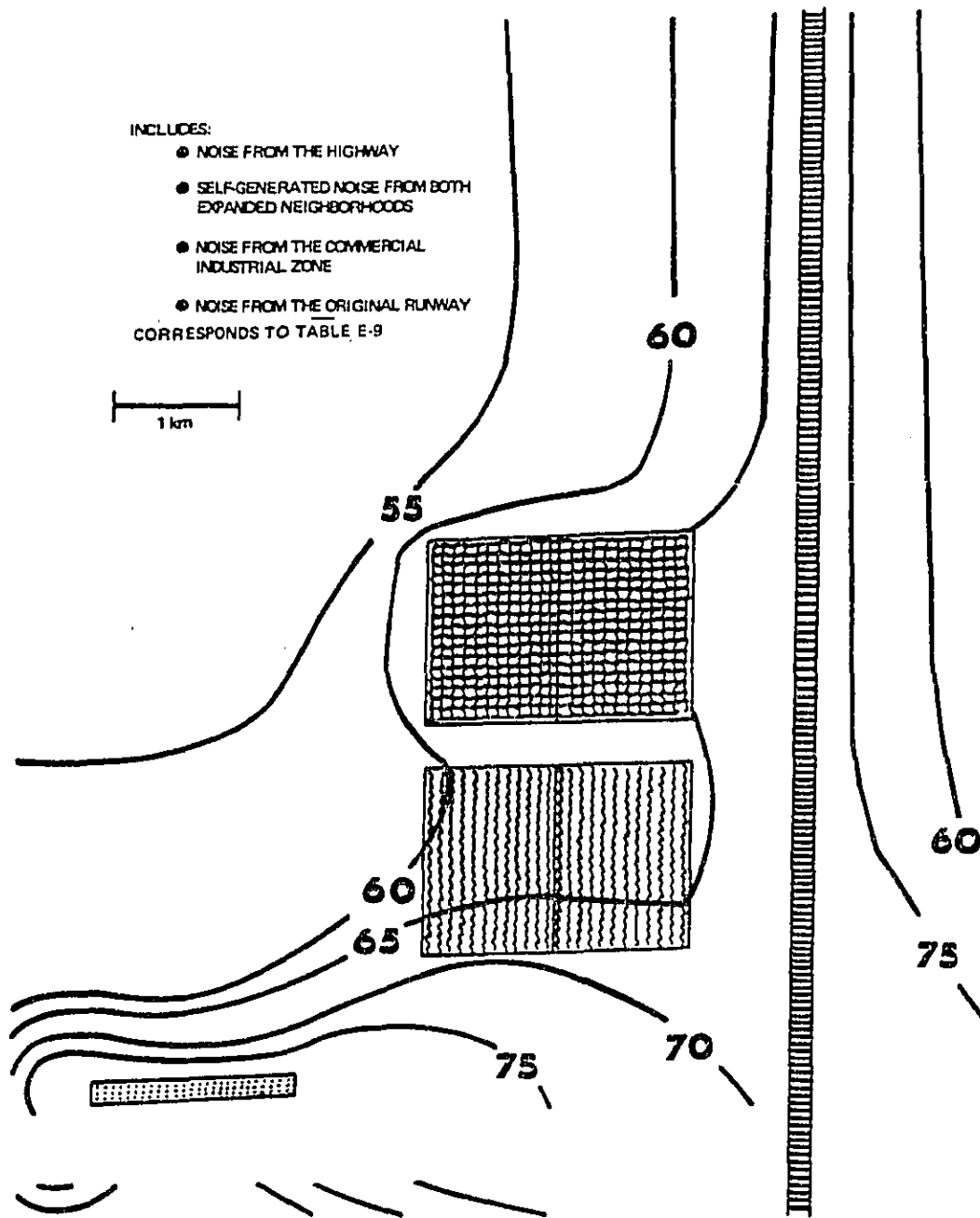

Figure E-12. Sample Data Presentation for the Airport Example; Future Noise Levels without the Proposed Project; 2001

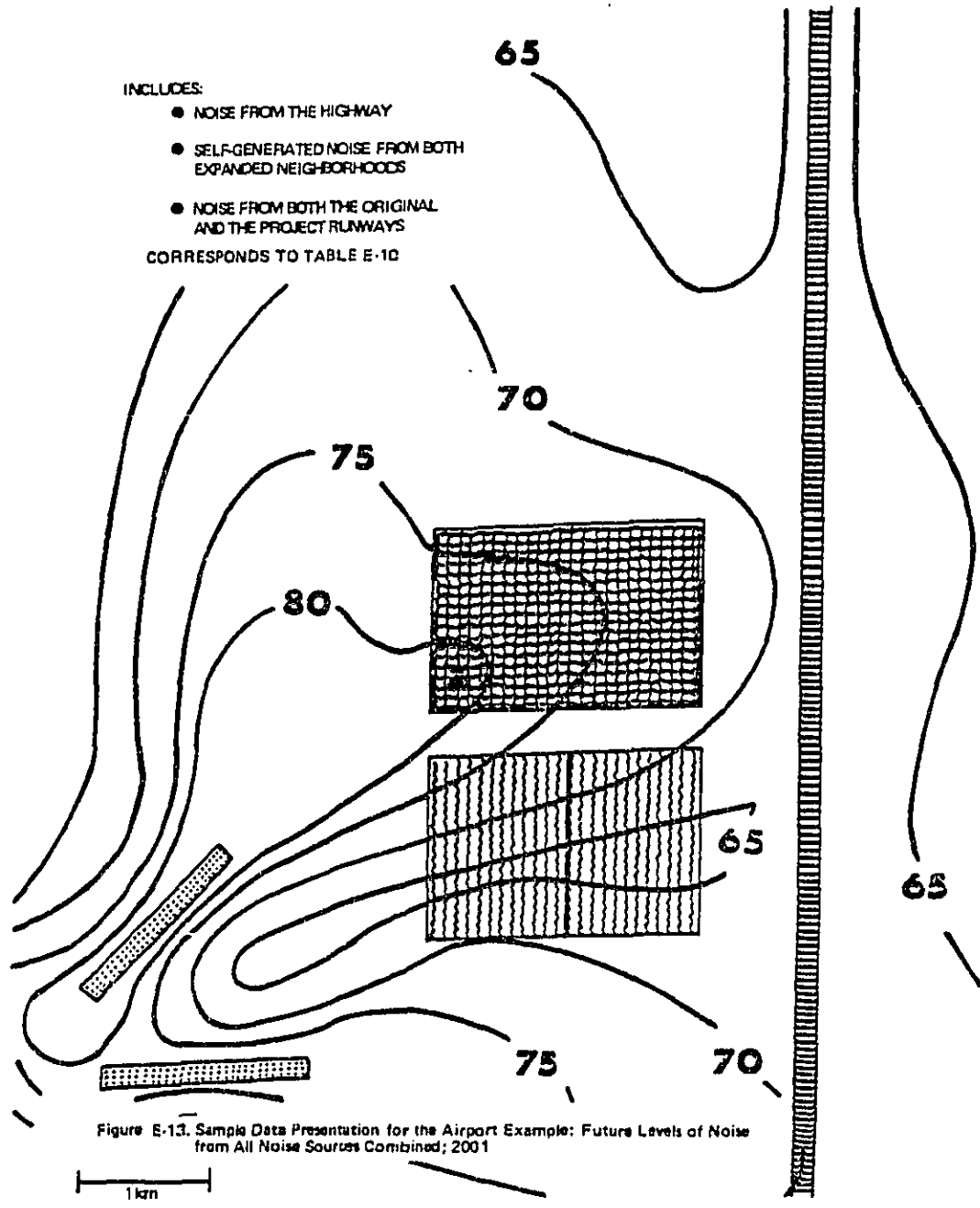

Figure E-13. Sample Data Presentation for the Airport Example: Future Levels of Noise from All Noise Sources Combined; 2001

E.2.4.3 Transferring the data to the tables. Tabulations of population and the area exposed are provided in Tables E-5, -6, -7, -8, -9, and -10, corresponding respectively to Figures E-8, -9, -10, -11, -12, and -13. The values in the tables are derived by summing the number of people and the area of land within each five decibel band. For example, in Figure E-13:

<u>Noise Level ($L_{dn}(y)$)</u>	<u>Residential Population</u>
80+	1,233
75-80	30,799
70-75	30,346
65-70	3,942
60-65	1,971
55-60	0
50-55	0

E.2.4.4 Calculating the single number indices. For this comparison, five single number indices should be considered: (1) the sound level-weighted population (LWP); (2) the noise impact index (NII); (3) the relative change of impact (RCI); (4) hearing loss-weighted population (HWP); and (5) the average potential hearing loss (PHL). The first three indices (explained in section 2.2.2.b) concern the range of general adverse noise effects; the latter two (explained in section 2.3.2) concerns noise levels which possibly may cause severe health effects. The indices LWP, NII, HWP and PHL should be computed for each of the tables.

TABLE E-5

SAMPLE DATA PRESENTATION FOR AIRPORT EXAMPLE:
 FUTURE LEVELS WITHOUT PROPOSED PROJECT; 1985

Yearly L _{dn} (dB)	Residential Population	Industrial/ Commercial Employees	Total Land Area (sq. km.)	Residential Land Area (sq. km.)	Industrial/ Commercial Land Area (sq. km.)
80-85	0	0	0	0	0
75-80	0	0	0	0	0
70-75	0	1,550	8	0	8.0
65-70	27,061*	7,264	42	3.14	38.86
60-65	4,628	10,822	19.2	4.48	14.72
55-60	0	6,814	135.8	0	135.8
<55	0	41,678	95.0	0	95.0
	31,689	68,128	300.0	7.62	292.38

Level Weighted Population (LWP) = 5,787
 Noise Impact Index (NII) = 0.183
 Hearing Loss-Weighted Population (HWP) = 0
 Average Potential Hearing Loss (PHL) = 0

Corresponds to Figure E-8
 Includes: o Highway noise
 o Self-generated noise from both neighborhoods
 o Noise from the original runway
 Note: Single number indices are not computed on the
 basis of industrial/commercial employees.

*Large number of people in the 65-70 dB band
 is attributable to high ambient noise levels
 (non-aircraft related) in the high density
 residential area (See section E.2.2.2).

TABLE E-6

SAMPLE DATA PRESENTATION FOR AIRPORT EXAMPLE:

FUTURE NOISE LEVELS OF PROJECT ALONE; 2001

Yearly L_{dn} (dB)	Residential Population	Industrial/ Commercial Employees	Total Land Area (sq. km.)	Residential Land Area (sq. km.)	Industrial/ Commercial Land Area (sq. km.)
80-85	1,233	303	12.0	0.16	11.84
75-80	30,799	19,473	20.7	4	16.7
70-75	30,346	22,921	49.15	4.85	44.3
65-70	2,673	25,431	206.03	1.32	204.71
60-65	3,240	0	12.12	12.12	22.97
55-60	0	0	0	0	0
<55	0	0	0	0	0
	68,291	68,128	300.0	22.45	277.55

Level Weighted Population (LWP) = 24,498
 Noise Impact Index (NII) = 0.359
 Hearing Loss-Weighted Population (HWP) = 408
 Average Potential Hearing Loss (PHL) = 0.09

Corresponds to Figure E-9
 Includes: o Noise from both the original and the
 additional runways.

TABLE E-7

SAMPLE DATA PRESENTATION FOR AIRPORT EXAMPLE:

FUTURE NOISE LEVELS OF PROJECT ALONE; 1985

Yearly L _{dn} (dB)	Residential Population	Industrial/ Commercial Employees	Total Land Area (sq. km.)	Residential Land Area (sq. km.)	Industrial/ Commercial Land Area (sq. km.)
80-85	0	0	0	0	0
75-80	0	0	0	0	0
70-75	0	5,934	25.6	0	25.6
65-70	5,358	18,708	82.76	2.12	80.64
60-65	26,331	11,349	74.0	5.50	68.5
55-60	0	22,132	92.64	0	92.64
<55	0	10,005	25.0	0	25.00
	31,689	68,128	300.0	7.62	292.38

Level Weighted Population (LWP) = 4,094
 Noise Impact Index (NII) = 0.129
 Hearing Loss-Weighted Population (HWP) = 0
 Average Potential Hearing Loss (PHL) = 0

Corresponds to Figure E-10
 Includes: o Noise from both the original and the
 additional runways.

TABLE E-8

SAMPLE DATA PRESENTATION FOR AIRPORT EXAMPLE:
 FUTURE LEVELS FROM ALL NOISE SOURCES COMBINED; 1985

Yearly L _{dn} (dB)	Residential Population	Industrial/ Commercial Employees	Total Land Area (sq. km.)	Residential Land Area (sq. km.)	Industrial/ Commercial Land Area (sq. km.)
80-85	0	0	0	0	0
75-80	0	0	0	0	0
70-75	0	5,934	25.6	0	25.6
65-70	29,331	18,708	85.76	5.12	80.64
60-65	2,358	17,354	76.0	2.50	73.5
55-60	0	26,132	112.64	0	112.64
<55	0	0	0	0	0
	31,689	68,128	300.0	7.62	292.38

Level Weighted Population (LWP) = 5,964
 Noise Impact Index = 0.188
 Hearing Loss-Weighted Population (HWP) = 0
 Average Potential Hearing Loss (PHL) = 0

Corresponds to Figure E-11
 Includes: o Highway noise
 o Self-generated noise from both neighborhoods
 o Noise from both the original and the project
 runways
 Note: Single number indices are not computed on the
 basis of industrial/commercial employees.

TABLE E-9

SAMPLE DATA PRESENTATION FOR AIRPORT EXAMPLE:

FUTURE LEVELS WITHOUT PROPOSED PROJECT; 2001

Yearly L _{dn} (dB)	Residential Population	Industrial/ Commercial Employees	Total Land Area (sq. km.)	Residential Land Area (sq. km.)	Industrial/ Commercial Land Area (sq. km.)
80-85	0	0	0	0	0
75-80	0	2,434	8.15	0	8.15
70-75	0	602	20.0	0	20.0
65-70	61,681	6,511	31.85	13.41	18.44
60-65	4,968	23,492	84.0	8.38	75.62
55-60	1,642	16,716	56.0	.66	55.34
<55	0	18,373	100.0	0	100.0
	68,291	68,128	300.0	22.45	277.55

Level Weighted Population (LWP) = 12,647
 Noise Impact Index = 0.185
 Hearing Loss-Weighted Population (HWP) = 0
 Average Potential Hearing Loss (PHL) = 0

Corresponds to Figure E-12
 Includes: o Highway noise
 o Self-generated noise from both expanded neighborhoods
 o Noise from the original runway
 Note: Single number indices are not computed on the basis of industrial/commercial employees.

TABLE E-10

SAMPLE DATA PRESENTATION FOR AIRPORT EXAMPLE:
 FUTURE LEVELS FROM ALL NOISE SOURCES COMBINED; 2001

Yearly L_{dn} (dB)	Residential Population	Industrial/ Commercial Employees	Total Land Area (sq. km.)	Residential Land Area (sq. km.)	Industrial/ Commercial Land Area (sq. km.)
80-85	1,233	303	12.0	0.16	11.84
75-80	30,799	19,473	20.7	4	16.7
70-75	30,346	22,921	49.15	4.85	44.3
65-70	3,942	25,431	184.3	2.56	181.74
60-65	1,971	0	33.85	10.88	22.97
55-60	0	0	0	0	0
55	0	0	0	0	0
	68,291	68,128	300.0	22.45	277.55

E-40

Level Weighted Population (LWP) = 24,597
 Noise Impact Index (NII) = 0.360
 Hearing Loss-Weighted Population (HWP) = 408
 Average Potential Hearing Loss (PHL) = 0.09

Corresponds to Figure E-13
 Includes: o Highway noise
 o Self-generated noise from both expanded neighborhoods
 o Noise from both the original and the project runways

Note: Single number indices are not computed on the basis of industrial/commercial employees.

A summary of the assessment results is presented below. Calculation of the level weighted population was based on the weighting function of equation 2b, shown in Table 3 of the main text.

Year	LWP	From Data In Example Table Number
Present (no project)	5,787	E-5
1985 without the project	5,787	E-5
1985 with the project	5,964	E-8
2001 without the project	12,647	E-9
2001 with the project	24,597	E-10

The Noise Impact Index, according to equation 7 in section 2.2.2.2, is simply the LWP divided by the total population.

Year	P _{Total}	LWP	NII	From Data In Example Table Number
Present (no project)	31,689	5,787	0.183	E-5
1985 without the project	31,689	5,787	0.183	E-5
1985 with the project	31,689	5,964	0.188	E-8
2001 without the project	68,291	12,647	0.185	E-9
2001 with the project	68,291	24,597	0.360	E-10

The Relative Change in Impact is calculated from equation 8.

Year	From Data on Airport		From Data in Example		RCI
	LWP _a	Table Number	LWP _b	Table Number	
1985	5,964	E-6	5,787	E-5	0.0306
2001	24,597	E-8	12,647	E-7	0.9449

As previously noted, the indices representing potential hearing damage risk are not similar to the other three indices. In order to emphasize the severity of the health problems caused by high noise levels, a separate

BEST COPY AVAILABLE

severe health effects single number index is used. As discussed in Section 2.3.1, for areas with an L_{dn} of 75 dB* or above, the following information should be estimated if possible: the population spending time out-of-doors; the length of time they are out-of-doors; the actual noise levels while they are out-of-doors. For this example, only the populations within the residential areas are being considered. Those people in other impacted areas of the metropolitan area are assumed to remain indoors (because the metropolitan area is entirely commercial/industrial, so they are not subjected to the noise.

The area for study of possible severe noise impact shown on Figure E-13 is expanded and shown as Figure E-14.

The additional information required is now assumed to have been collected through additional estimates or survey work. It is listed on the next page as Table E-11.

The next step is to obtain the at-ear outdoor L_{eq} values of the exposure instead of the L_{dn} values. The best way is to take additional noise measurements. A much less preferable way, as explained in Section 3.2.1, is to use the approximation:

$$L_{eq} = L_{dn}(\text{daytime}) - 3$$

This approximation may be used if the difference between the daytime and nighttime levels is the typical one where the nighttime level is approximately 4 dB lower. It has been assumed in this example that sufficient measurements were taken to determine that the day-night difference in L_{eq} of that area is a typical one. Thus, the 3 dB correction term has been applied and the results entered in Table E-11.

*As pointed out in Section 2.3.1, the L_{dn} should be used only to identify potential problem areas.

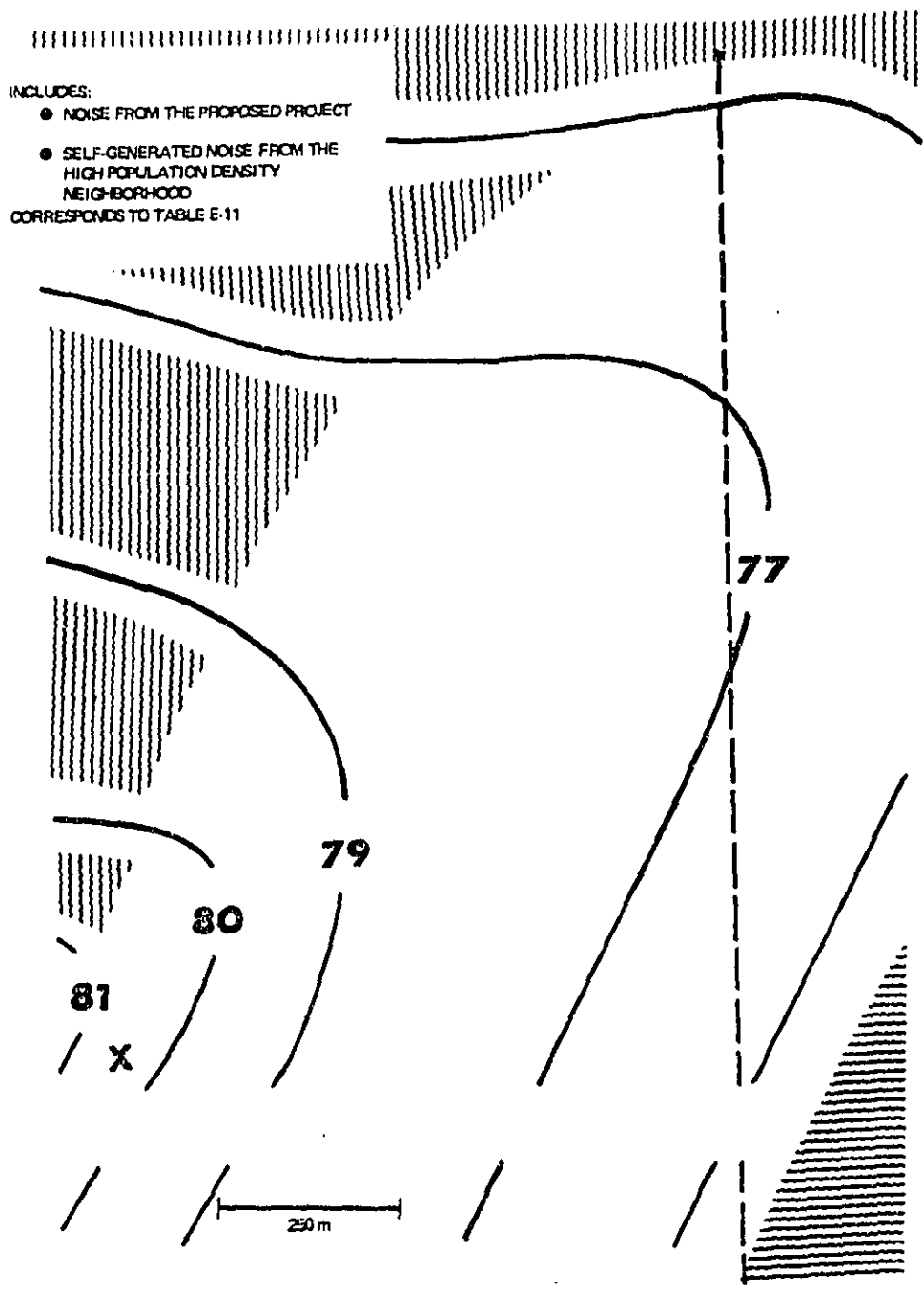

Figure E-14. Sample Data Presentation for the Airport Example: Severe Health Analysis Area

Table E-11

Sample Data Presentation for Example the Airport: Information required to calculate the PHL

Contour (L _{dn})	Residential Population	Median Contour (L _{dn})	Residential Population [Exposures in L _{eq} (8)]				Estimated L _{eq}
			Time Outdoors				
			4 hr	6 hr	8 hr	12 hr	
75-77	12,574	76	7,521 [70]	1,259 [72]	2,794 [73]	1,000 [75]	73
77-79	9,474	78	6,378 [72]	1,583 [74]	819 [75]	694 [77]	75
79-81	8,953	80	5,899 [74]	2,542 [76]	287 [77]	225 [79]	77
81-83	1,031	82	691 [76]	176 [78]	97 [79]	67 [81]	79
TOTAL	32,032		20,489	5,560	3,997	1,986	

* Calculated as explained in Section

Corresponds to Figure E-14

E-44

Next, since not all residents are exposed to exactly eight hours of outdoor noise, the data in Table E-11 are adjusted to the appropriate $L_{eq}(8)$ values, using Table E-12. For example, the population of 7,521 exposed to 4 hours of $L_{eq}(4) = 73$ dB has the equivalent of an $L_{eq}(8)$ exposure of 70 dB. These L_{eq} 's have been entered into the cells of Table E-11 in brackets ([]). Now the number of people exposed to various levels of noise over $L_{eq}(8) = 75$ may be read from Table E-11:

$L_{eq}(8)$	Population Distribution as a Function of 8-hour L_{eq}
76	(2542 + 691) = 3,233
77	(694 + 287) = 981
78	176
79	(225 + 97) = 322
80	0
81	67
	TOTAL 4,779

PHL may thus be computed from equation 13 as:

$$PHL = \frac{P(L_{eq})_i \cdot H(L_{eq})_i}{P_{Total}}$$

where $P(L_{eq})$ is the population distribution as a function of 8-hour L_{eq} (shown above), $H(L_{eq})$ is the corresponding weighting function shown on Table 5 of the main text for all $P(L_{eq})_i$ where $H(L_{eq})_i \geq 0$, and P_{Total} is the population for the severe health effects area, i.e., the sum of all people exposed to an $L_{eq}(8)$ greater than 75 dB. Using the information in Table E-11, the PHL is:

$$PHL = \frac{[[P(81) \times W(81)] + [P(80) \times W(80)] + [P(79) \times W(79)] + [P(78) \times W(78)] + [(P(77) \times W(77))] + [P(76) \times W(76)]]}{4779}$$

TABLE E-12
 CONVERSION OF $L_{eq}(x)$ TO $L_{eq}(8)$ AND $L_{eq}(24)$

$$\begin{aligned}
 L_{eq}(1) &= L_{eq}(8) - 9 = L_{eq}(24) - 14 \\
 L_{eq}(2) &= L_{eq}(8) - 6 = L_{eq}(24) - 11 \\
 L_{eq}(3) &= L_{eq}(8) - 4 = L_{eq}(24) - 9 \\
 L_{eq}(4) &= L_{eq}(8) - 3 = L_{eq}(24) - 8 \\
 L_{eq}(5) &= L_{eq}(8) - 2 = L_{eq}(24) - 7 \\
 L_{eq}(6) &= L_{eq}(8) - 1 = L_{eq}(24) - 6 \\
 &L_{eq}(8) &= L_{eq}(24) - 5 \\
 L_{eq}(10) &= L_{eq}(8) + 1 = L_{eq}(24) - 4 \\
 L_{eq}(12) &= L_{eq}(8) + 2 = L_{eq}(24) - 3 \\
 L_{eq}(16) &= L_{eq}(8) + 3 = L_{eq}(24) - 2
 \end{aligned}$$

$$\text{PHL} = \frac{[(67) \times (0.9)] + [(0) \times (0.625)] + [(322) \times (0.4)] + [(176) \times (0.225)] + [(981) \times (0.1)] + [(3233) \times (0.025)]}{4779}$$

$$\text{PHL} = \frac{408}{4779} = 0.09$$

E.2.5 Conclusions of the noise analysis

The purpose of the noise analysis is to compare the number of people affected by the noise levels with and without the project. To do this comparison, the single number indices are used. In tabular form, they are shown in Table E-13. These indices show: 177 more people in the residential areas will be fully adversely affected by the noise created by the project in 1985 (when compared with the existing situation or with 1985 without the project); 18,810 more people in the residential areas will be fully adversely affected by the noise from the project in 2001 (when compared with the existing situation); 11,950 more people will be fully adversely affected by the noise created by the project in 2001 (when compared with 2001 without the project). In addition, the PHL for the year 2001 increases from 0 to 0.09.

Footnote to the highway and airport examples:

Step-by-step explanation of combination of noise contours from different sources.

How are the noise levels on Figures E-2 and E-4 combined?

Using Table E-14, combine the noise levels shown on Figures 2 and 4 by determining the difference between levels at the same point, and adding the appropriate amount from the table to the higher level.

TABLE E-13
SUMMARY OF AIRPORT EXAMPLE

Single Number Index	Without the Project		With the Project		Difference Between the Existing & 1985 with the Project	Difference Between the Existing & 2001 with the Project	Difference Between 1985 without the Project and 1985 with the Project	Difference Between 2001 without the Project and 2001 with the Project
	Existing and 1985	2001	1985	2001				
LWP (people)	5,787	12,647	5,964	24,597	177	18,810	177	11,950
NII	0.183	0.185	0.188	0.360	0.005	0.177	0.005	0.175
RCI	-	-	-	-	For 1985: 0.0306		For 2001: 0.9449	
PHL	0	0	0	0.09	0	0.09	0	0.09

E-48

TABLE E-14

Difference between Levels in decibels	Number of decibels to be added to Higher Level
0	3.0
1	2.6
2	2.1
3	1.8
4	1.5
5	1.2
6	1.0
7	0.8
8	0.6
9	0.5
10	0.4
12	0.3
14	0.2
16	0.1

For example, the noise level at the first row of houses is 60 dB in Figure E-2 and 65 dB in Figure E-4, a difference of 5 decibels. Table E-14 shows that for a difference of 5 dB, approximately 1 dB should be added to the higher level in order to derive the total level. Therefore, the noise level at the first row of duplexes in Figure E-5 is computed as 66 dB. Similarly, the noise level contour at the second row of houses is 64 dB. Table E-15 shows these calculations.

TABLE E-15

Duplex Row	Figure E-2	Figure E-4	Difference	Add to Higher Level	Figure E-5
1	60	65	5	1.2 or 1	66
2	58	62	4	1.5 or 2	64
3	56	58	2	2.1 or 2	60
4	55	54	1	2.6 or 3	58
5	54	53	1	2.6 or 3	57
6	53	51	2	2.1 or 2	55
7	53	49	4	1.5 or 2	55
8	53	48	5	1.2 or 1	54
9	52	48	4	1.5 or 2	54
10	52	47	5	1.2 or 1	53
11	51	47	4	1.5 or 2	53

PARTIAL BIBLIOGRAPHY OF MODELS
FOR PREDICTING NOISE LEVELS FROM VARIOUS SOURCES

Highway Noise

- U.S. Environmental Protection Agency, Office of Noise Abatement and Control. Comparison of Highway Noise Prediction Models. EPA 550/9-77-355. May, 1977.
- U.S. Environmental Protection Agency, Office of Noise Abatement and Control. Highway Noise Impact. EPA 550/9-77-356. May, 1977.
- U.S. Department of Transportation, Transportation Systems Center. User's Manual For the Prediction Of Road Traffic Noise Computer Programs. DOT-TSC-315-1. May, 1972.
- National Academy of Sciences, Highway Research Board. Highway Noise - a Design Guide For Engineers. Report 117. 1971.
- National Academy of Sciences, Highway Research Board. Highway Noise - A Field Evaluation of Traffic Noise Reduction Measures. Report 144. 1973.
- U.S. Department of Transportation, Federal Highway Administration. A Revised Program and User's Manual for the FHWA Level I Highway Traffic Noise Prediction Computer Program. FHWA-DP-45.4. December, 1980.
- U.S. Department of Transportation, Federal Highway Administration. User's Manual: FHWA Level II Highway Traffic Noise Prediction Model. FHWA-RD-78-138. May, 1979.

Aircraft Noise

- U.S. Environmental Protection Agency, Office of Noise Abatement and Control. Calculation of Day-Night Levels (L_{dn}) Resulting From Civil Aircraft Operations. EPA 550/9-77-450. January, 1977.
- U.S. Department of Transportation, Federal Aviation Administration, Office of Environmental Quality. Federal Aviation Administration Integrated Noise Model. April, 1978.
- U.S. Department of Transportation, Federal Aviation Administration, Office of Environmental Quality. Federal Aviation Administration Integrated Noise Model Version I. FAA-EQ-78-01. January, 1978.

U.S. Department of Defense, Air Force Aerospace Medical Research Laboratory. Community Noise Exposure Resulting From Aircraft Operations: Computer Program Description, AMRL-TR-73-109, November, 1974. Computer Program Operator's Manual, AMRL-TR-108, July, 1974. NOISE MAP 3.4 Computer Program Operator's Manual, AMRL-78-109, December, 1978.

Rapid Transit Noise

U.S. Department of Transportation, Urban Mass Transportation Administration, Office of Technology Development and Deployment, Office of Rail and Construction Technology, Noise Rating Criteria for Elevated Rapid Transit Structures. Report No. UMTA-MA-06-0099-79-3. May, 1979.

Transmission Line Noise

Comber, M.G., and L.E. Zaffanella. "Audible Noise." In: Transmission Line Reference Book 345 KV and above. Published by Electric Power Research Institute, 3412 Hillview Avenue, Palo Alto, CA 94304, 1975.

Driscoll, D.A., and F.G. Haag. "Prevention and Control of Environmental Noise Pollution in New York State." In: Proceedings of a Workshop on Power Line Noise as Related to Psychoacoustics. Published by the Institute of Electrical and Electronics Engineers, Inc., 345 East 47th St., New York, NY 10017, 1976.

Molino, J.A., G.A. Zerdy, N.D. Lerner, and D.L. Harwood. "Psychoacoustic Evaluation of the Audible Noise From EHV Power Lines." National Bureau of Standards. To be published.

Kolcio, N., J. DiPlacido, and F.M. Dietrich. "Apple Grove 750 KV Project - Two-Year Statistical Analysis of Audible Noise from Conductors at 755 KV and Ambient Noise Data." In: IEEE Transactions on Power Apparatus and Systems, 1977.

Outdoor Recreational Noise

Harrison, R.T., R.N. Clark, and G.H. Stankey; "Predicting Impact of Noise on Recreationists." U.S. Department of Agriculture, Equipment Development Center. ED&T Project No. 2688. April, 1980.

High-Energy Impulsive Noise

Siskind, D.E., V.J. Stachura, M.S. Stagy, and J.W. Kopp, "Structure Response and Damage Produced by Airblast From Surface Mining." U.S. Department of the Interior, Bureau of Mines. Report of Investigation 8485. 1980.

Schomer, P.D., L.L. Little, D.L. Effland, V.I. Pawlowska, and S.G. Roubik, "Blast Noise Prediction Volume I: Data Bases and Computational Procedures." U.S. Army Construction Engineering Research Laboratory. Technical Report N-98, March, 1981.

Reed, J.W., "Atmospheric Attenuation of Explosive Waves," The Journal of the Acoustical Society of America, 61 (1), pp. 39-47, 1977.

Maglieri, D.J., H.W. Carlson and H.H. Hubbard, "Status of Knowledge of Sonic Booms," Noise Control Engineering, 15 (2), pp. 57-64, 1980.